

One

55"/65"/75" Chassis - Camera Above

Assembly Guide

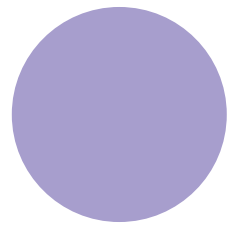
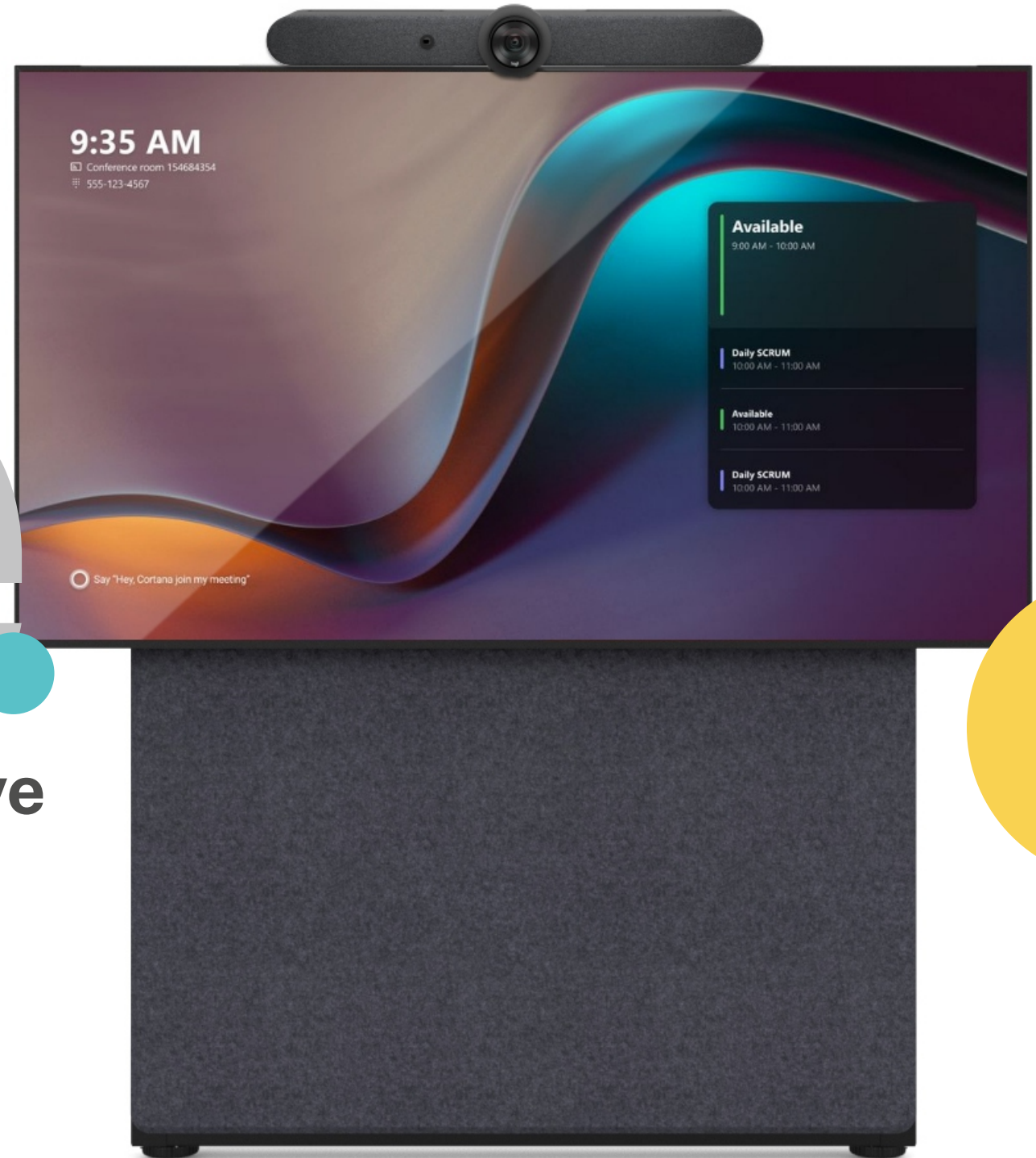

AB One - 55"/65"/75" - Camera Above.

Assembly Guide



Please read before proceeding.

Before proceeding with assembly, connection, and operation, please ensure that you read this document fully, and any additional documentation that may be included with the product.

Please keep this Assembly Guide for future reference.

We have tried to make this Assembly Guide as simple as possible to follow, however we are always keen to improve. So if you find anything that is not clear or inaccurate, please let us know by sending your suggestions to: support@ashtonbentley.com.

Trademark Information

Ashton Bentley®, and the names and marks associated with Ashton Bentley Group Limited's products, are trademarks and/or service marks of Ashton Bentley Group Limited, and are registered and/or common law marks in the United Kingdom and various other countries. All other trademarks are property of their respective owners.

Patent Information

The accompanying product is protected by one or more UK, EU, US, and foreign patents and/or pending patent applications held by Ashton Bentley Technology Limited.

No part of this documentation may be reproduced or transmitted in any form or by any means, electronic or mechanical, for any purpose, without the express written permission of Ashton Bentley Group Limited. Under the law, reproducing includes translating into another language or format. As between the parties, Ashton Bentley Group Limited retains title to and ownership of all proprietary rights with respect to the software contained within its products.

Any software is protected by copyright laws and international treaty provision. Therefore, the software must be treated like any other copyrighted material (e.g., a book or sound recording).

Every effort has been made to ensure that the information in this manual is accurate. Ashton Bentley Group Limited is not responsible for printing or clerical errors. Information in this document is subject to change without notice.

www.ashtonbentley.com

23 Schooner Court, Crossways Business Park, Dartford, DA2 6NW, United Kingdom.

© 2023 Ashton Bentley Group Limited, All rights reserved.

1. Important Safety Information

AB One - 55"/65"/75" - Camera Above.

Assembly Guide



Important safety information.

General

The following information and precautions should always be followed to reduce the risk of damage, fire, electric shock or injury to people. If in any doubt about installation, operation or maintenance please contact your vendor or Ashton Bentley.

- Follow all warnings and instructions in this document and marked on the equipment.
- Allow plenty of space in the construction area.
- Never operate the system outdoors or in very humid conditions or allow ingress of any liquid.
- Always use suitable cable management or install under a raised floor to avoid trip hazards.
- Do not block or cover any ventilation vents in the products.

Displays, Chassis and Tables.

As some parts are large and heavy, we recommend two people assemble. If tethering a Chassis to a wall using the supplied Ashton Bentley Wall Brackets, ensure the wall is solid and stable, and that suitable fixings (not provided) as used.

Recommendations and warnings.

Symbols are used where extra attention is required. For example, if an item is heavy and requires a minimum number of personnel.

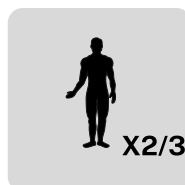

Electrical.

If the incoming mains electrical feed is unstable or prone to transient input voltage spikes of more than 1KV, we recommend the use of a surge protector connected to the power input cable.

If any of the following are noticed, then do not use the product until everything is back to a fully safe state:

- Power cables, plugs, power supplies/adapters, extension cords, surge protectors that are broken or damaged.
- Signs of overheating, smoke, sparks, or fire.
- Signs of liquid ingress or an object has fallen onto the electronic elements of product, the power cable, or power supply/adapter.

Note:

Never wrap a power cable around a power supply/adapter or other object. Always route power cables so that they will not be walked on, tripped over, or pinched by objects.

Do not use any power supply/adapter that shows corrosion at the ac input pins or shows signs of overheating (such as deformed plastic).

The power cable and supply/adapter provided with this product are intended to be used with this product only. Do not use them with any other products. The use of 3rd party power supplies/adapters will invalidate the warranty.

Do not use your system, or disconnect any cables or perform installation, maintenance, or reconfiguration of this product during an electrical storm.

Any product not supplied by Ashton Bentley should not be used if any of the above or other faults are experienced. Immediately disconnect from the Ashton Bentley product and any power supply, and contact the product manufacturer for further instructions, or until you get a suitable replacement.

2. Product Components

AB One - 55"/65"/75" - Camera Above.

Assembly Guide



Product Components.

The product is supplied in one or more boxes. Please ensure you have all boxes as listed below.

Please inform your vendor immediately if any boxes are damaged, or contents missing.

Each box will have a label attached that identifies what it contains, plus some additional information. Some labels have more details than others depending on contents.

A sample label looks like this:

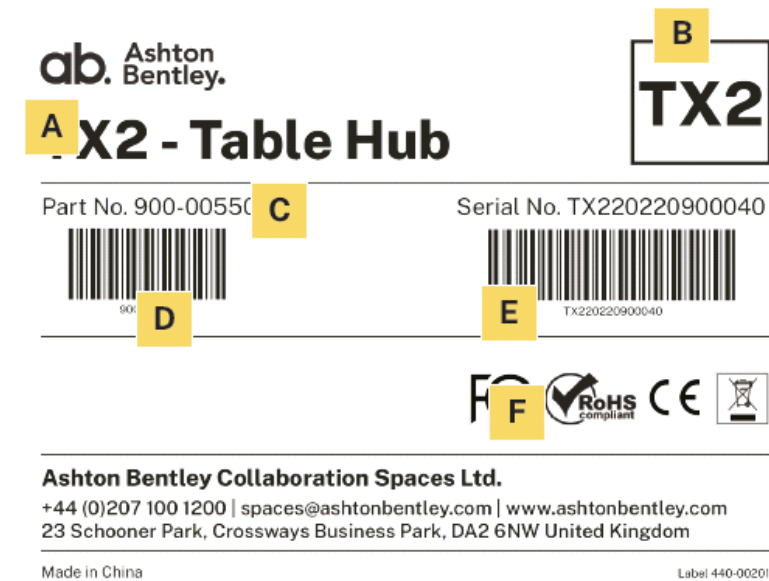

- A: Product Description
- B: Carton ID
- C: Part Number
- D: Part Number Barcode
- E: Serial Number
- F: Compliance & Conformity

3. How to use this Assembly Guide

AB One - 55"/65"/75" - Camera Above.

Assembly Guide

How to use this Assembly Guide.

Product Components

The product is supplied in several cartons. Each carton has a label that contains information about the contents and a Carton ID which can be located as shown below:

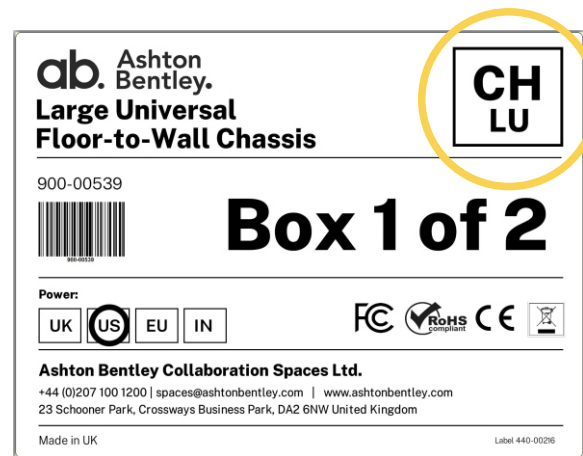

Carton ID

Carton ID is referenced in the instructions so you can locate the parts required at that point of assembly.

For example, in the instructions:

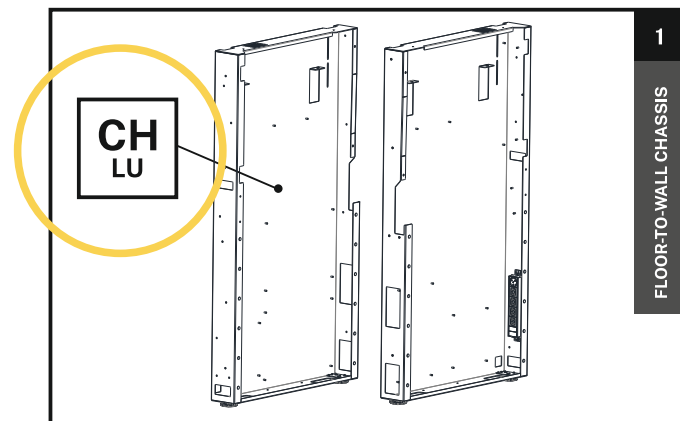

AB Knobs

The product is assembled using AB Knobs that are designed to be tightened by hand. Always ensure all knobs are secure before proceeding to the next step.

Some parts require particular attention, and these are indicated as follows:



Important instruction

The following symbols show the correct procedure.

Incorrect



Correct



4. Pre-Installation

AB One - 55"/65"/75" - Camera Above.

Assembly Guide

Notes.

Make sure the work area is clear and safe. Wear any appropriate PPE.

Check if any items are heavy and require more personnel.

If using any power tools, follow all safety protocols.

If integrating with any other manufactures products make sure that these are set-up according to the manufacturer's instructions.

Ensure that any local electrical codes are followed.

Floor Grommet Placement Dimensions.

Floor to wall chassis (shown with 55" Display)

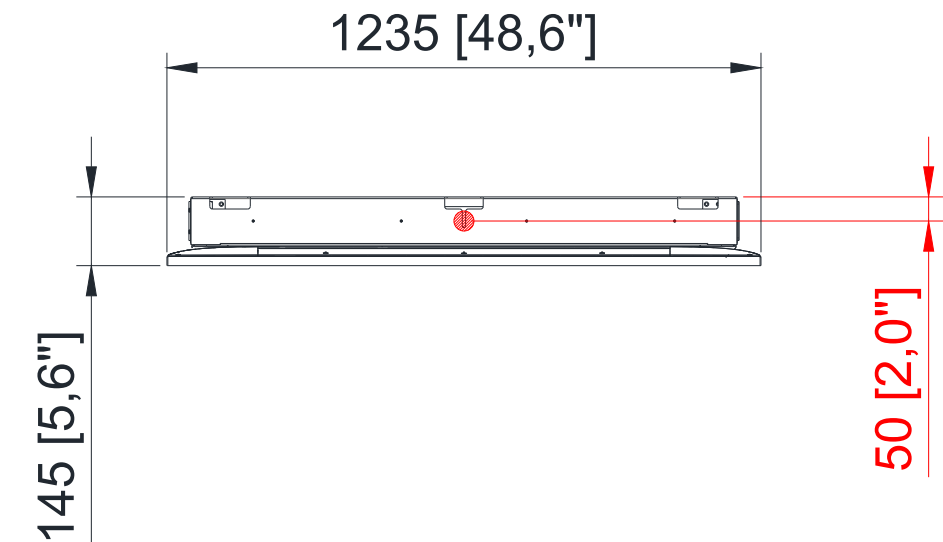

Chassis with Freestanding Base (shown with 55" Display)

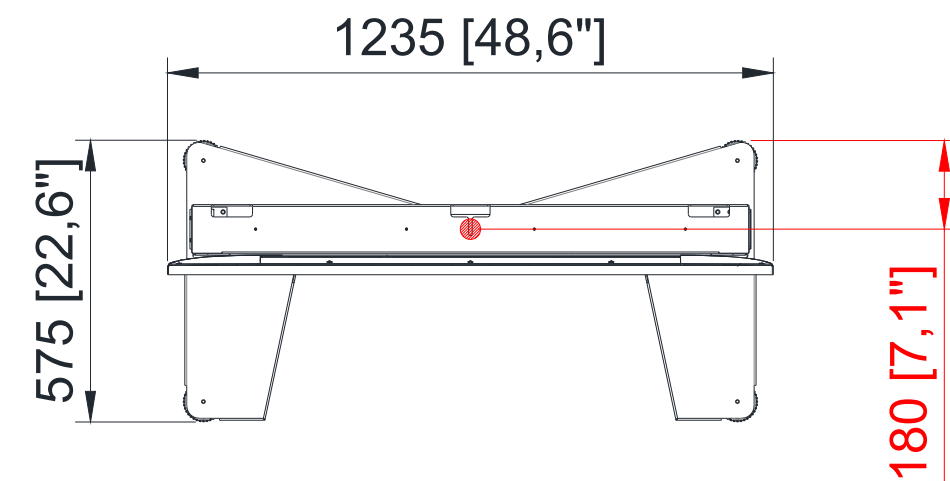

5. Base Options

AB One - 55"/65"/75" - Camera Above.

Assembly Guide

1

FLOOR-TO-WALL

55/65/75
CH

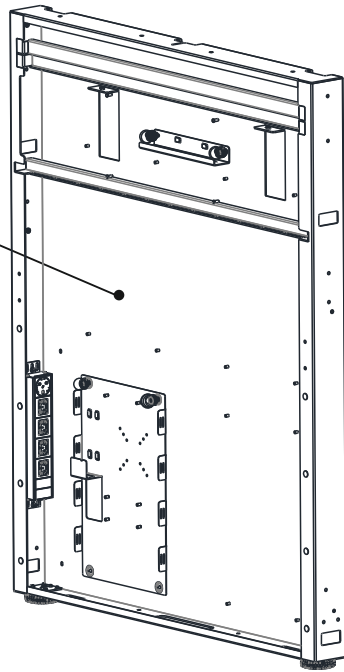

The floor-to-wall chassis is designed to minimize the footprint of the product and keep the system as flush to the wall as possible. The System does require tethering to the wall, however the connection isn't load bearing but simply a means of preventing the system from toppling forward.

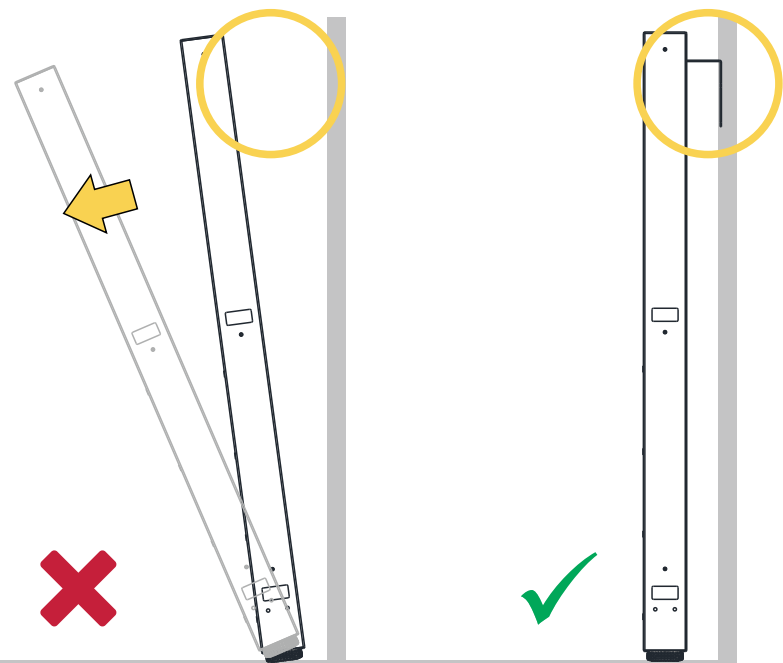

WALL FIXINGS NOT SUPPLIED

2

FREESTANDING

FSB

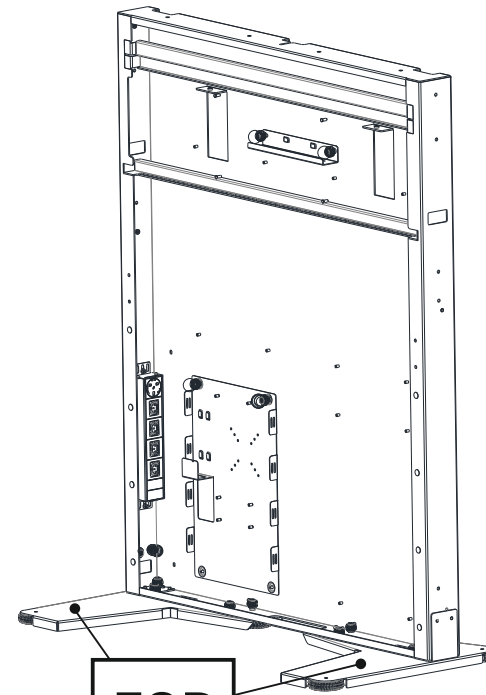

The freestanding base allows the chassis system to be placed in free-space or against glass partitions and requires NO BUILDING WORKS to secure it or support it in anyway.

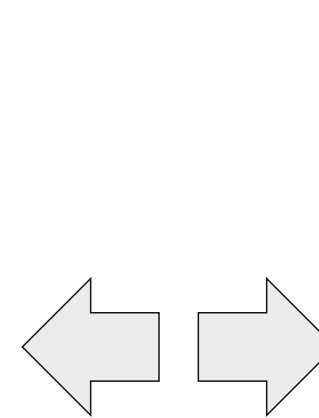

3

MOBILE

MB

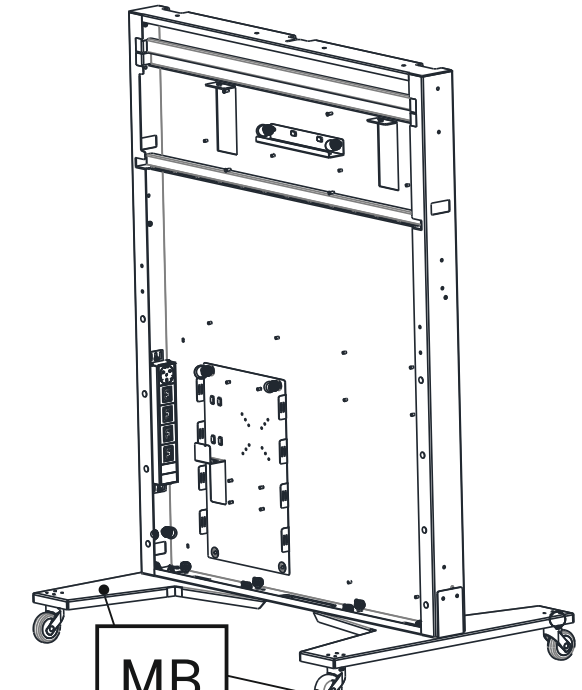

The mobile base comes complete to allow the systems to be mobile and be deployed knowing that its location may change, making it very flexible and available wherever required.

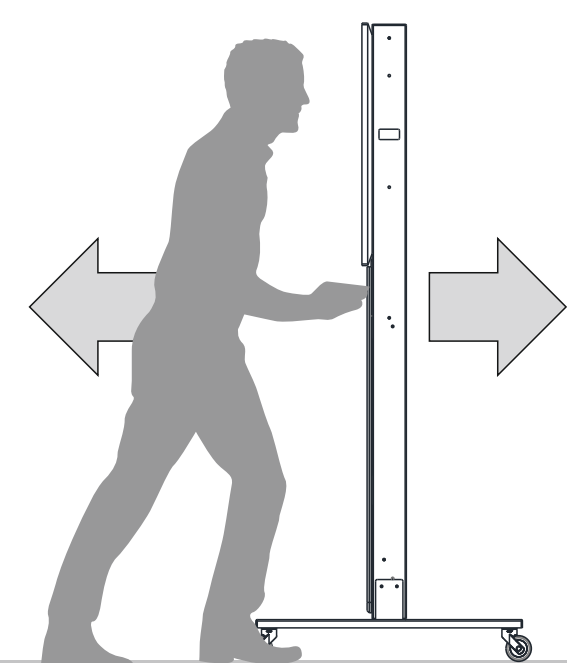

AB One - 55"/65"/75" - Camera Above.

Assembly Guide

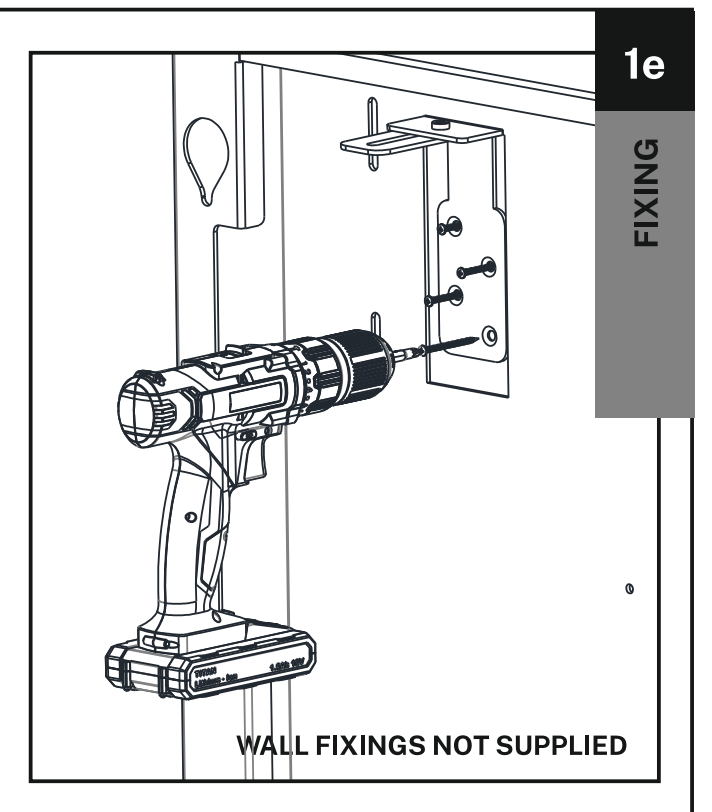
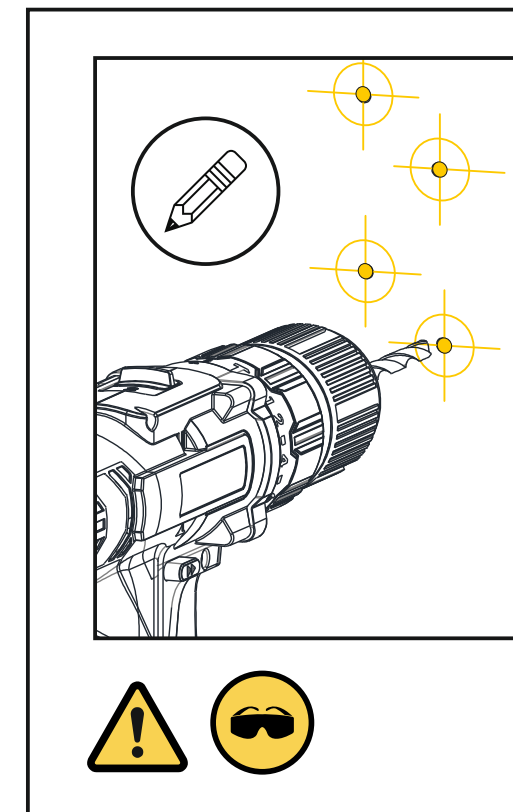
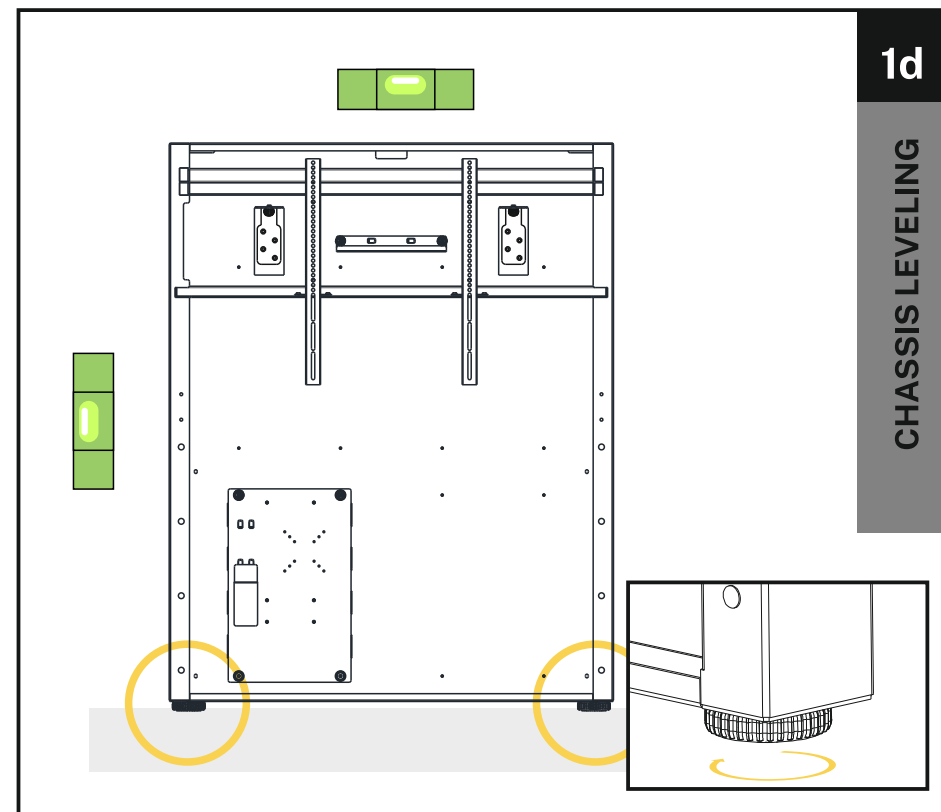
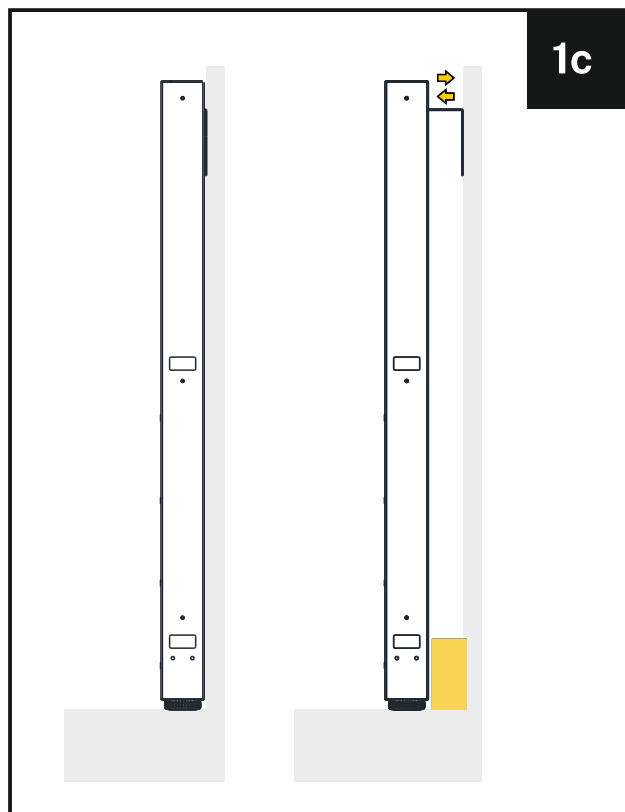
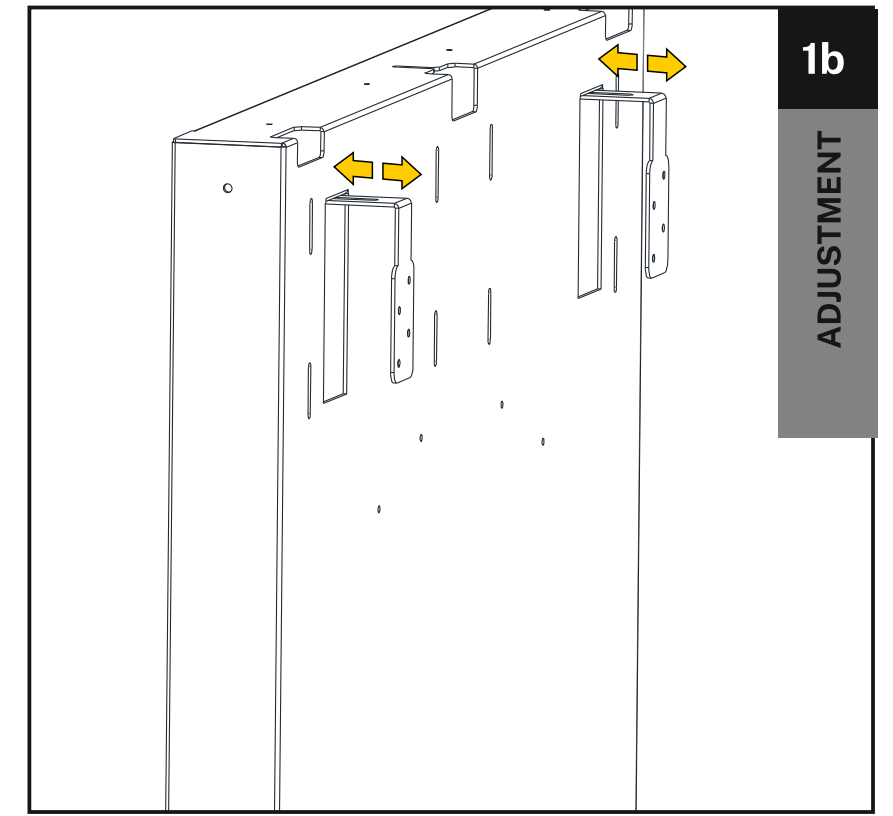
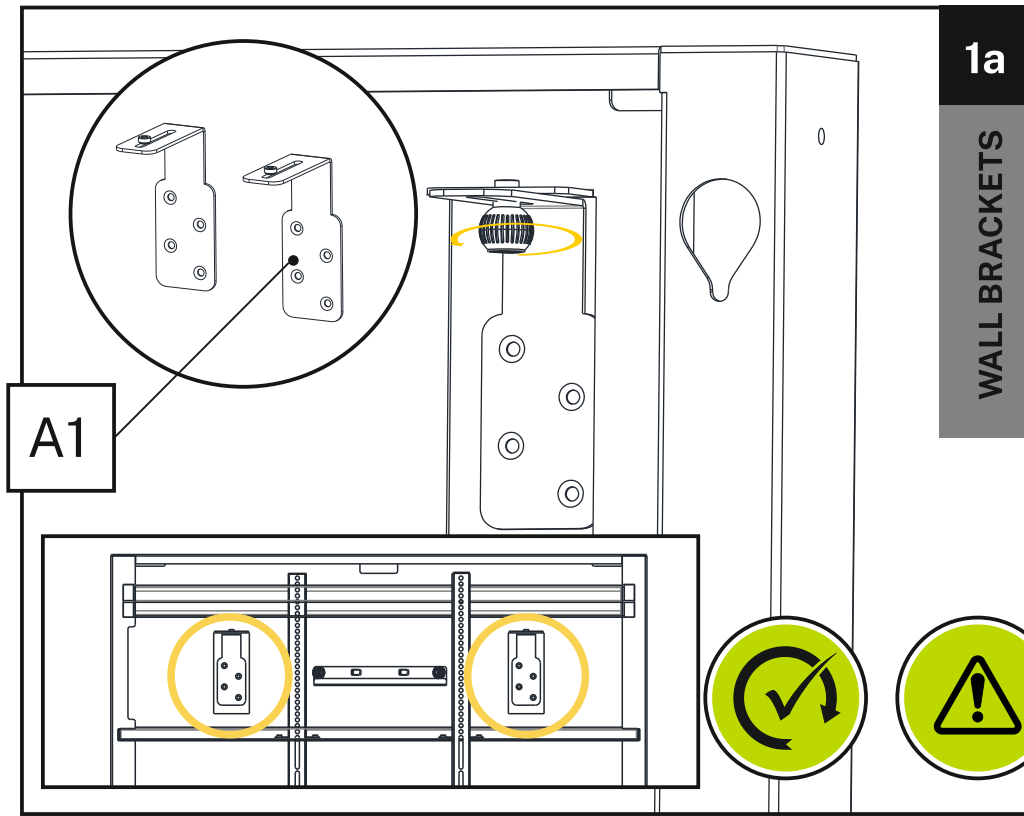
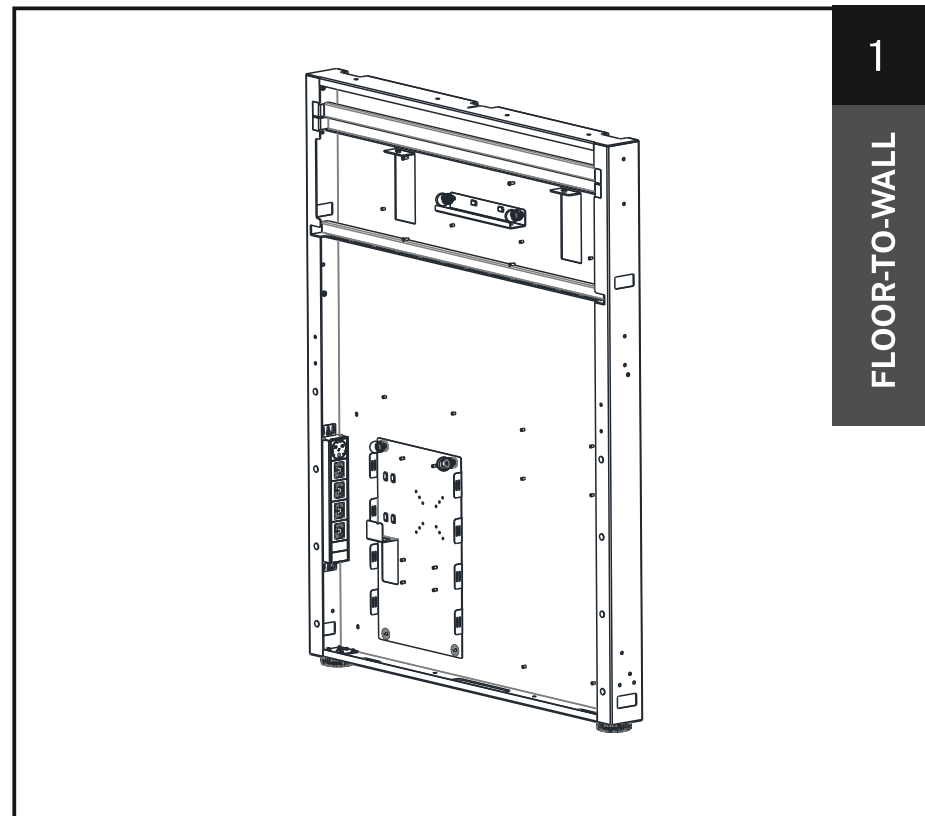

AB One - 55"/65"/75" - Camera Above.

Assembly Guide

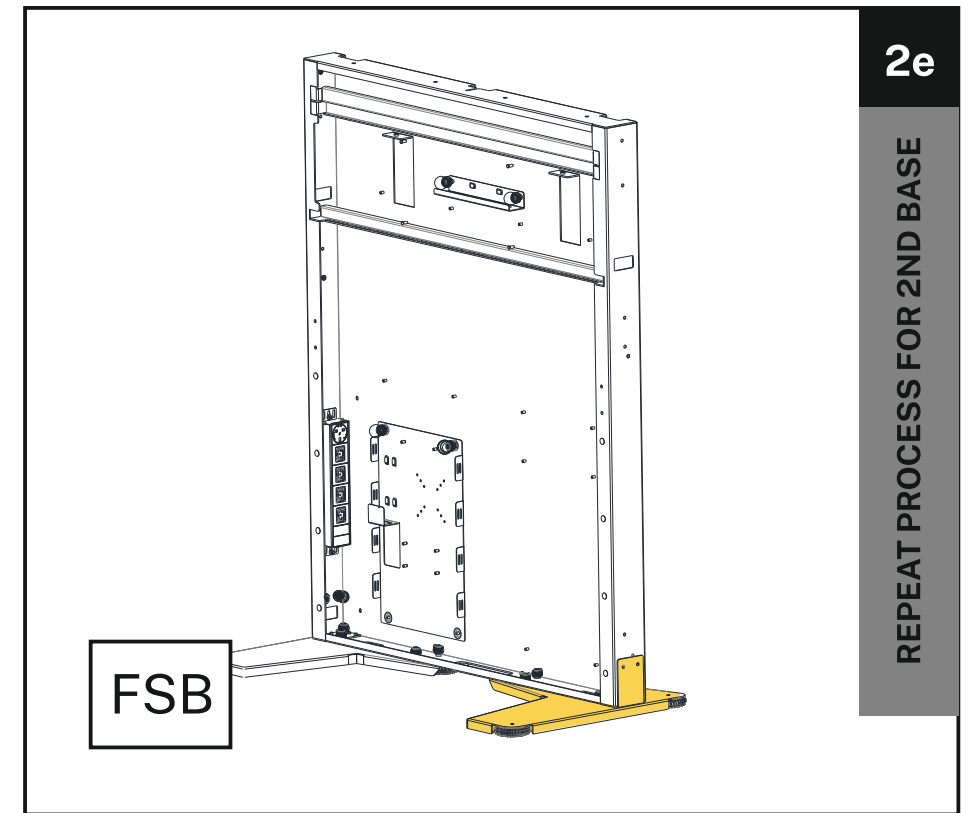
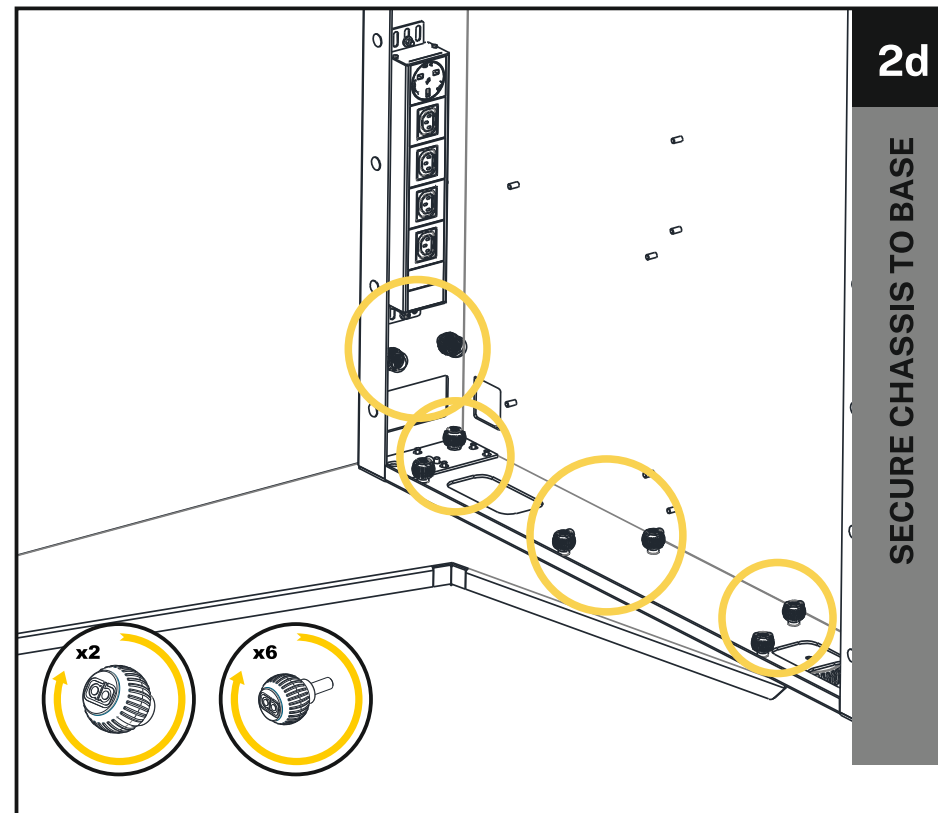
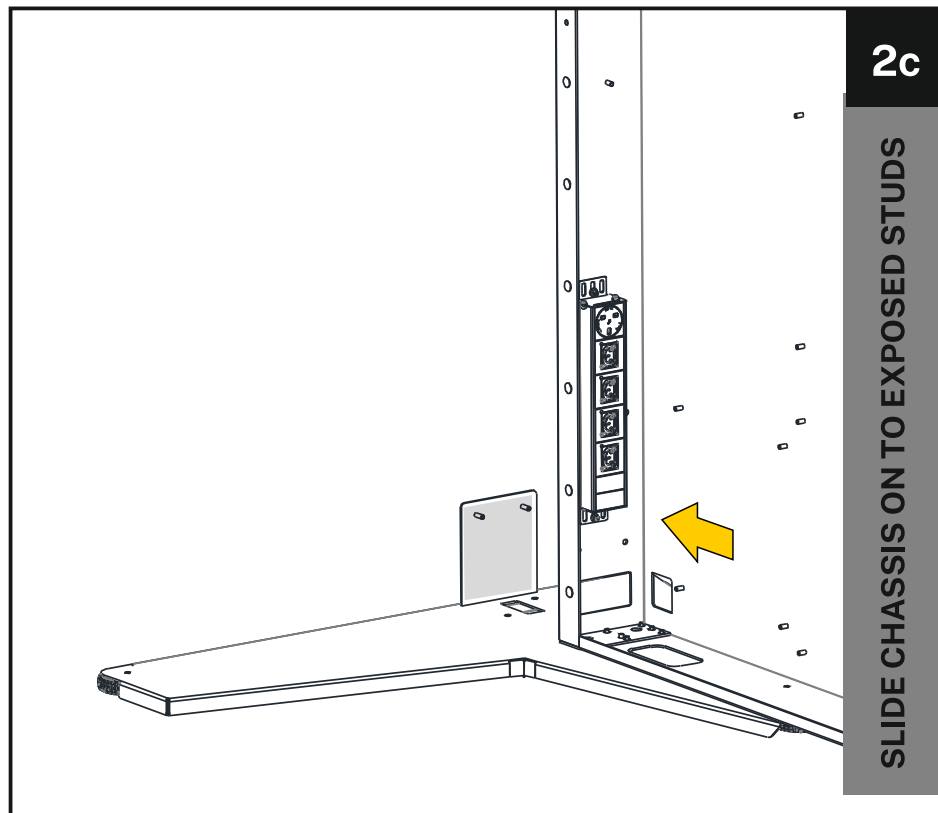
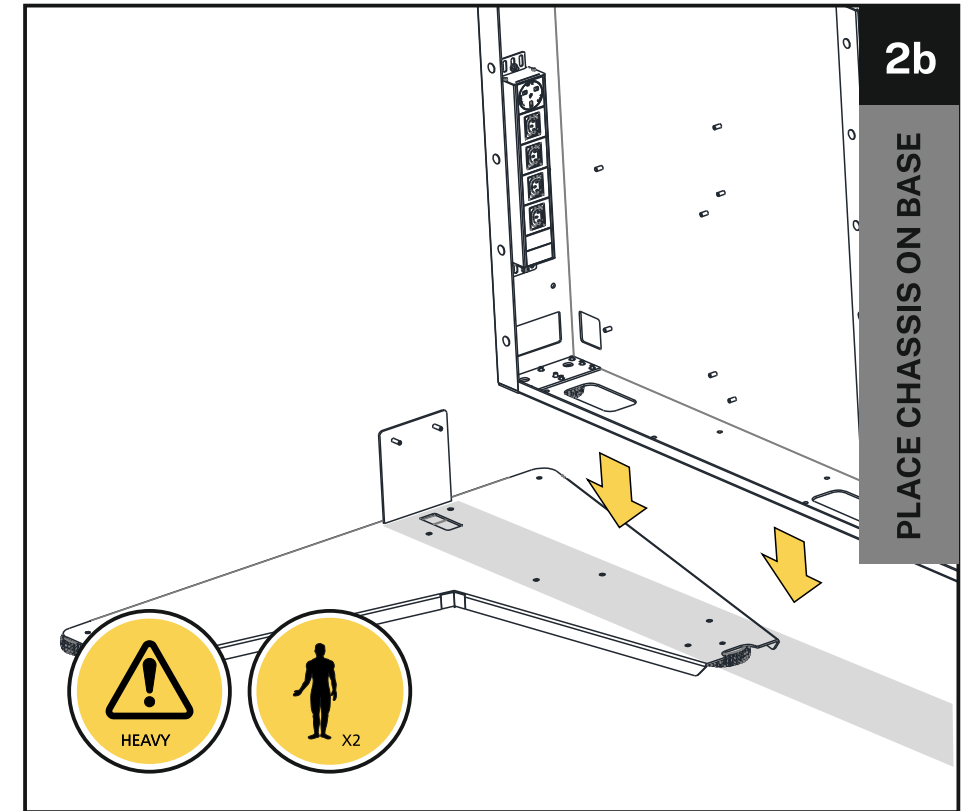
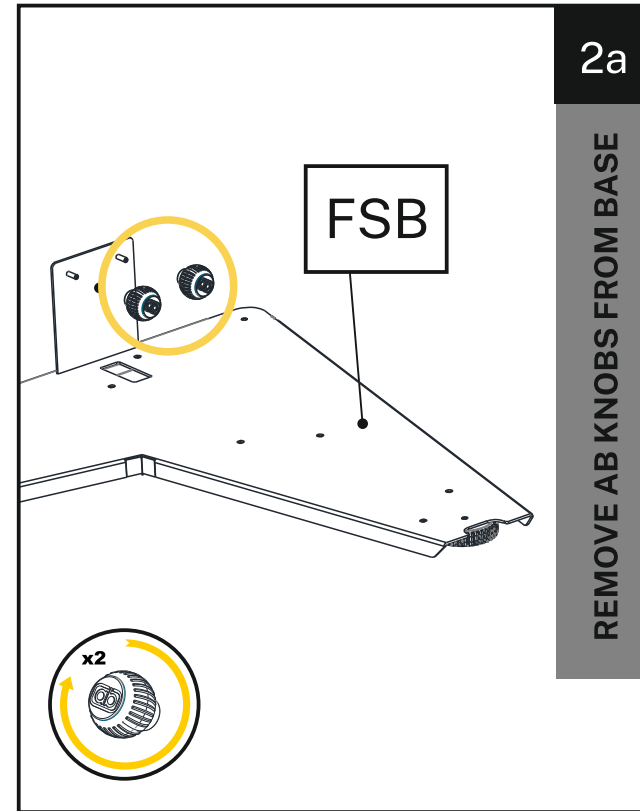
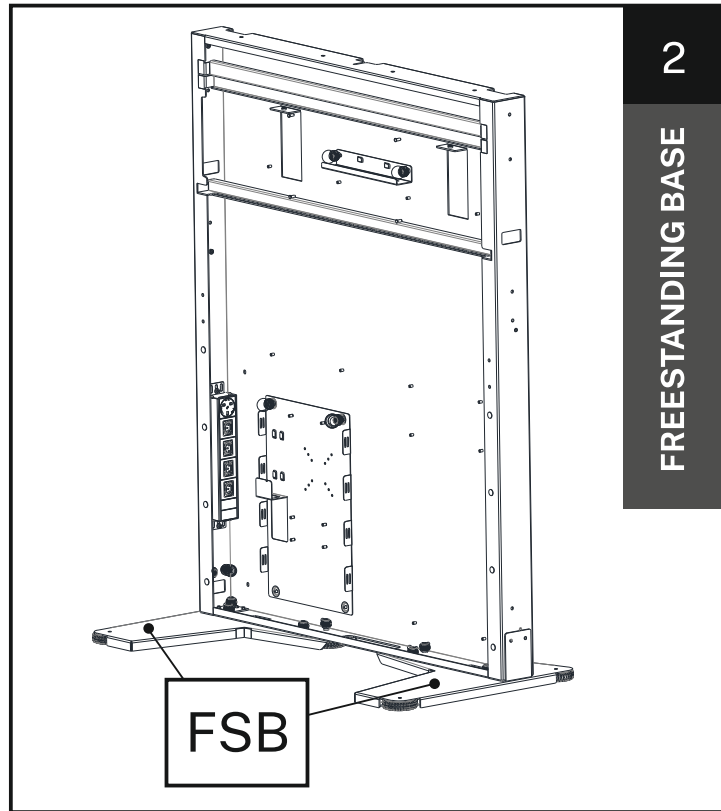

AB One - 55"/65"/75" - Camera Above.

Assembly Guide

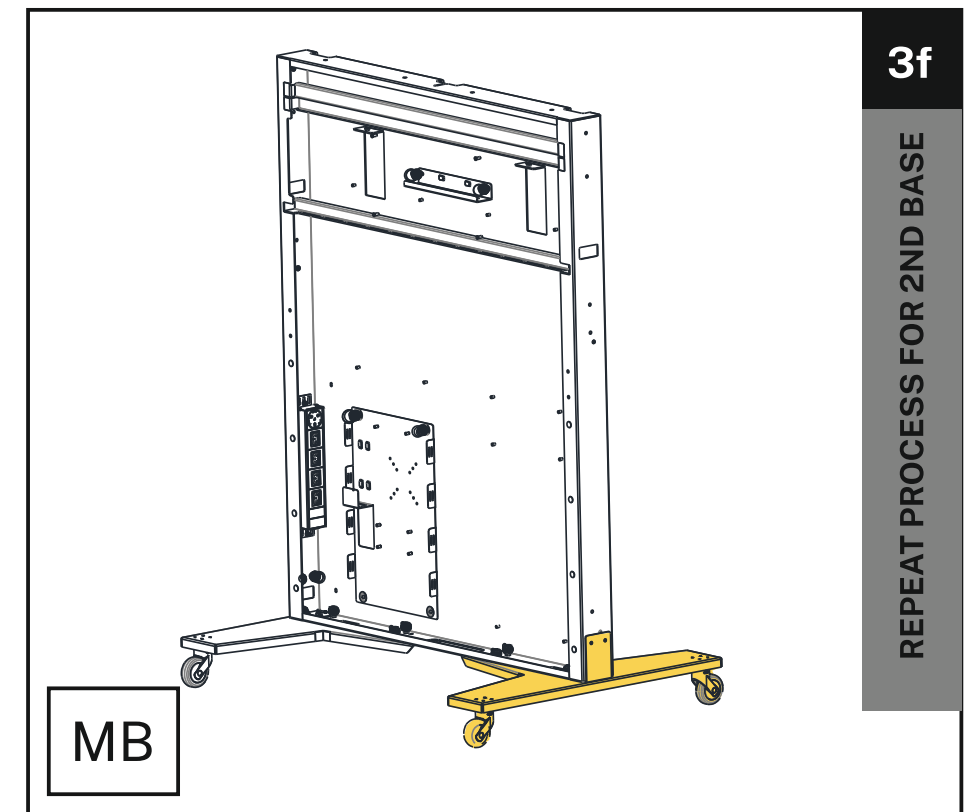
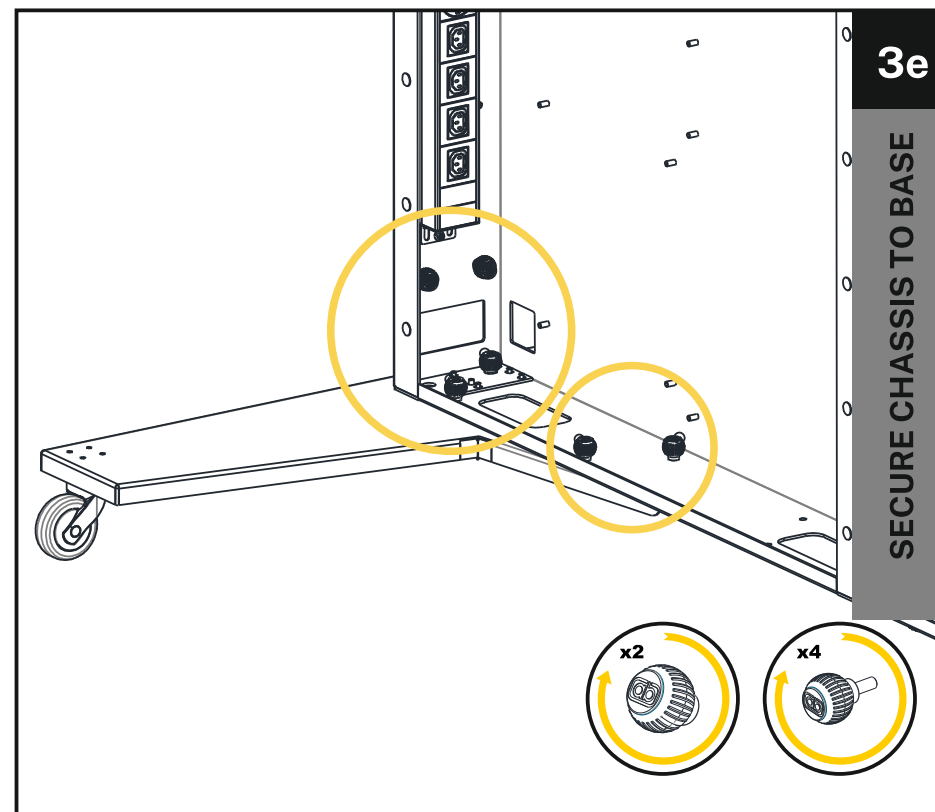
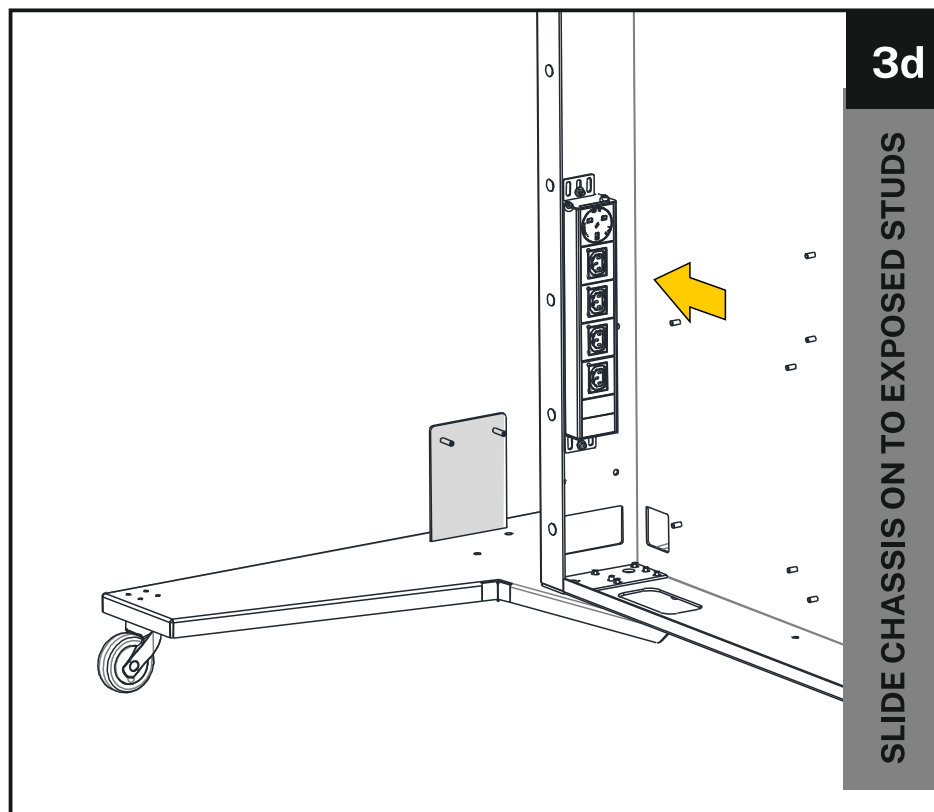
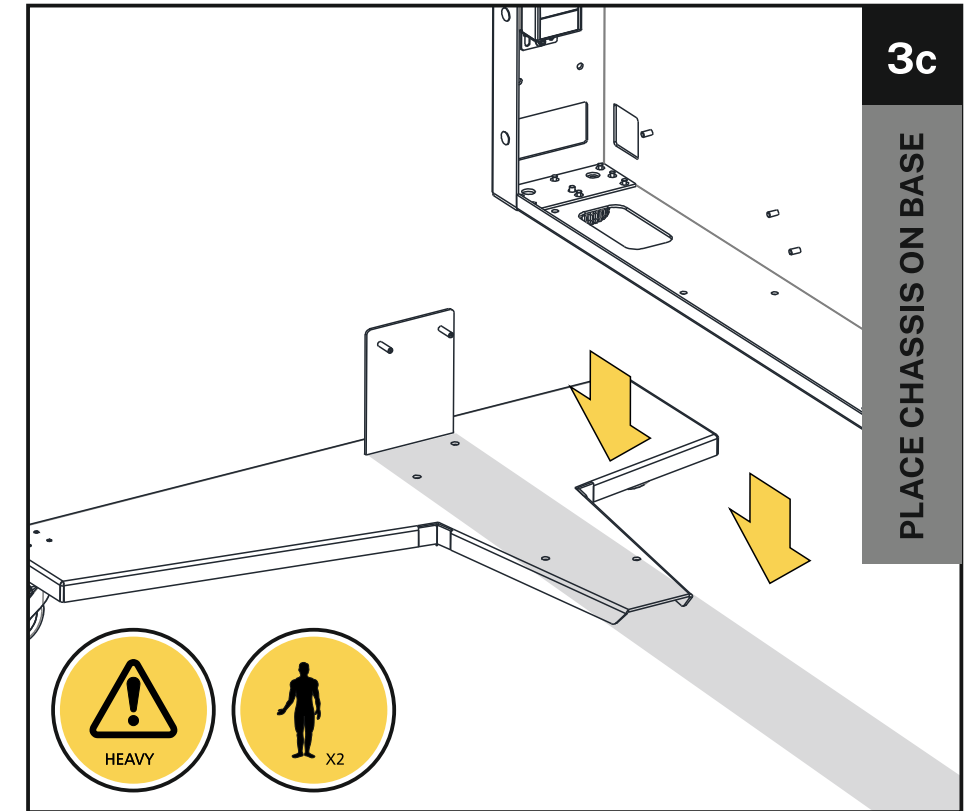
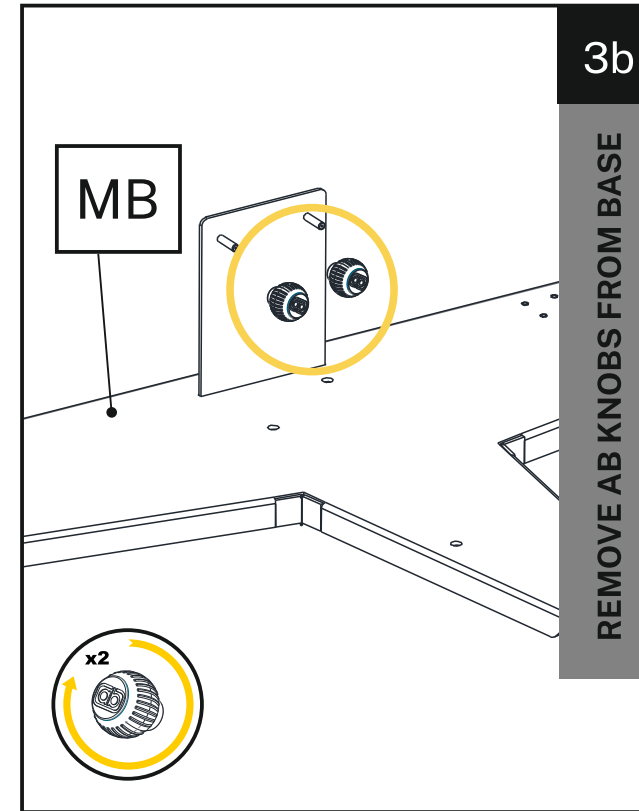
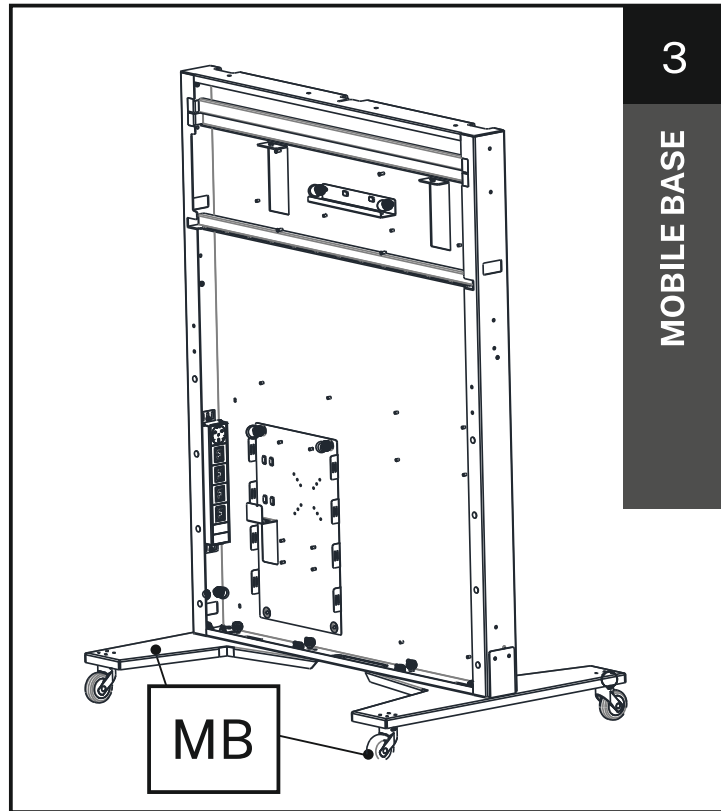

6. Chassis Assembly

AB One - 55"/65"/75" - Camera Above.

Assembly Guide

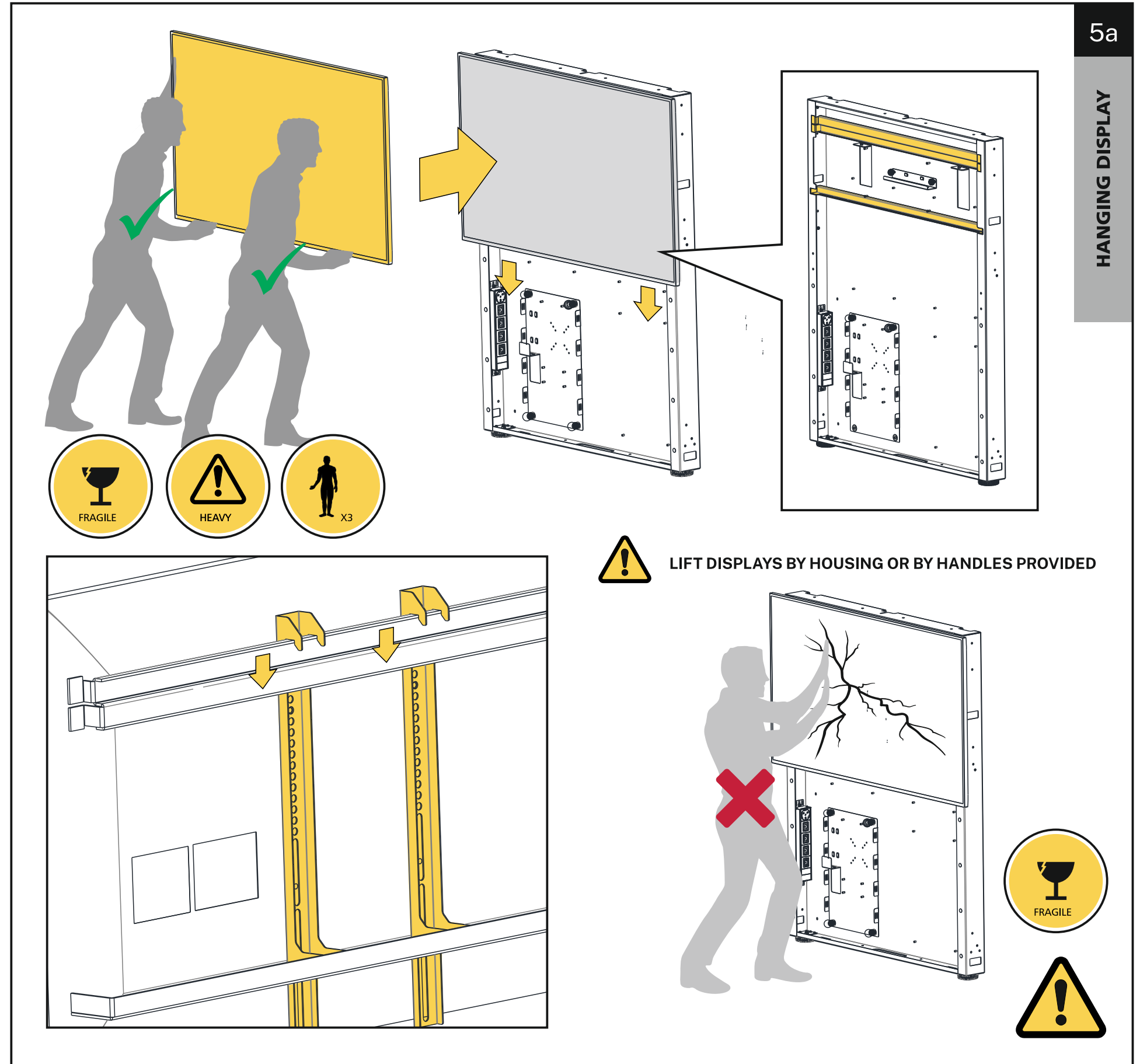
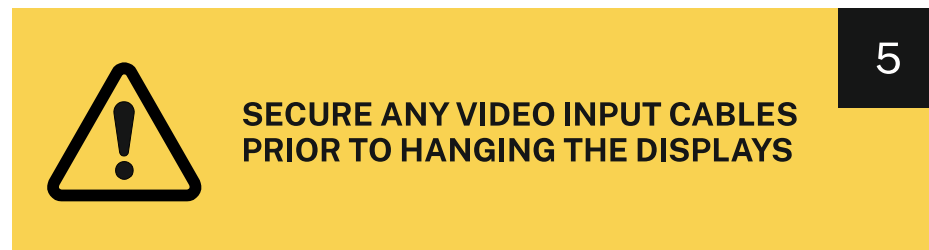
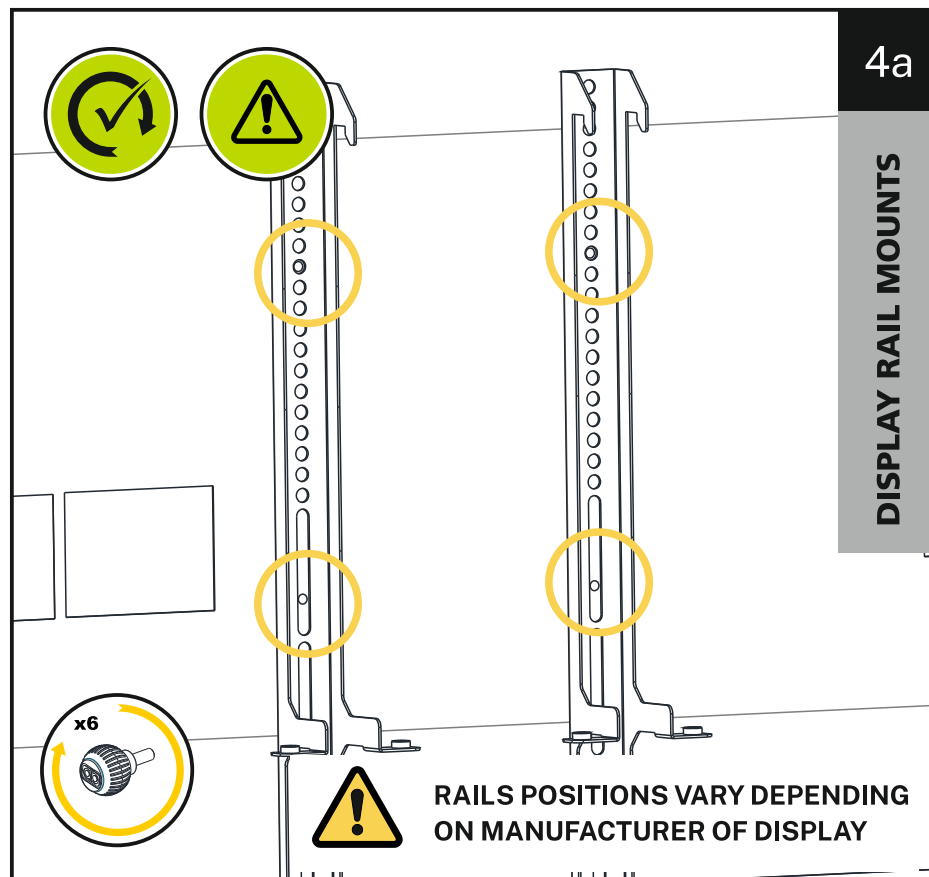
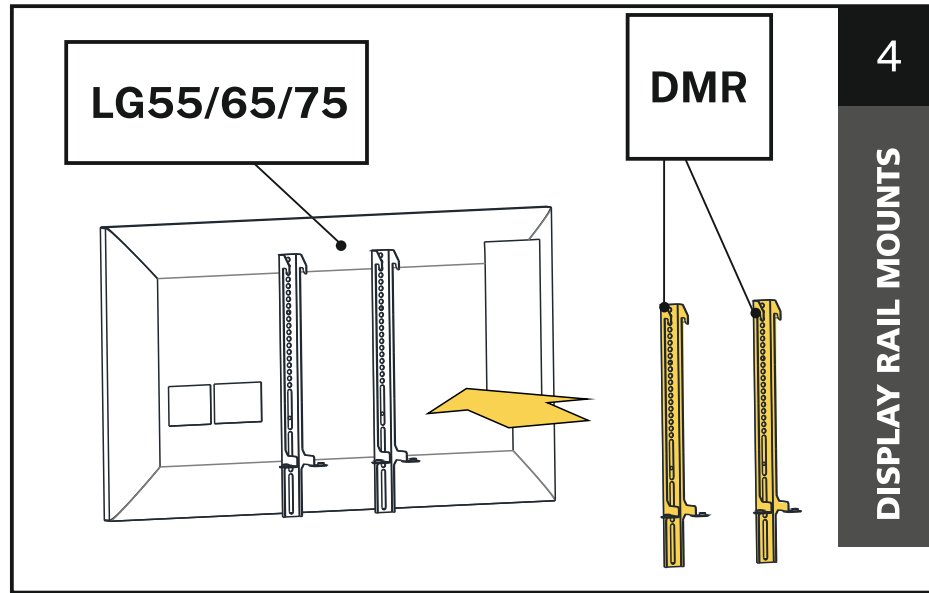

AB One - 55"/65"/75" - Camera Above.

Assembly Guide

TOP OF DISPLAY

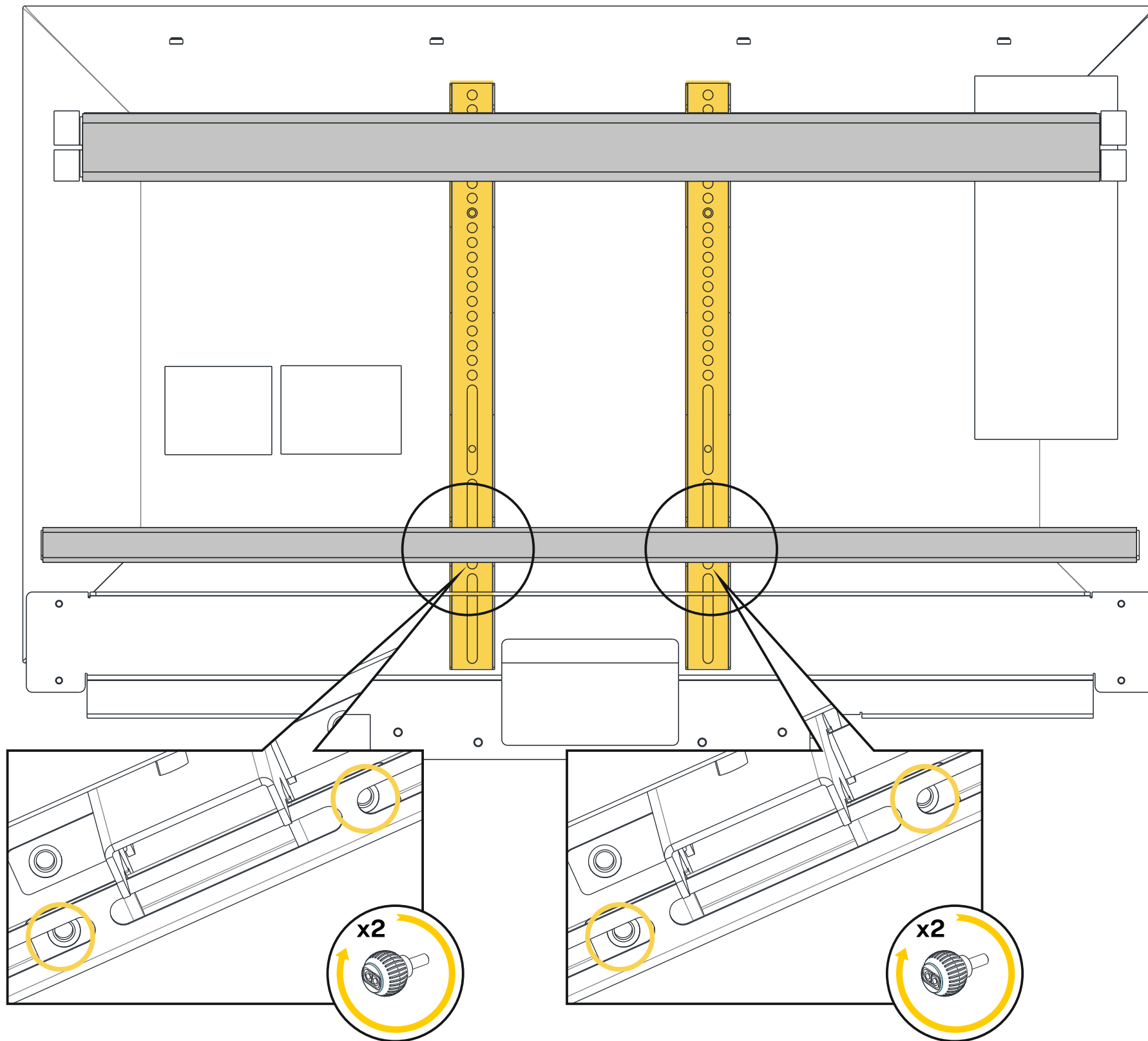

SECURING DISPLAYS PREVENTS ACCIDENTAL DAMAGE OR THE DISPLAYS BEING REMOVED.

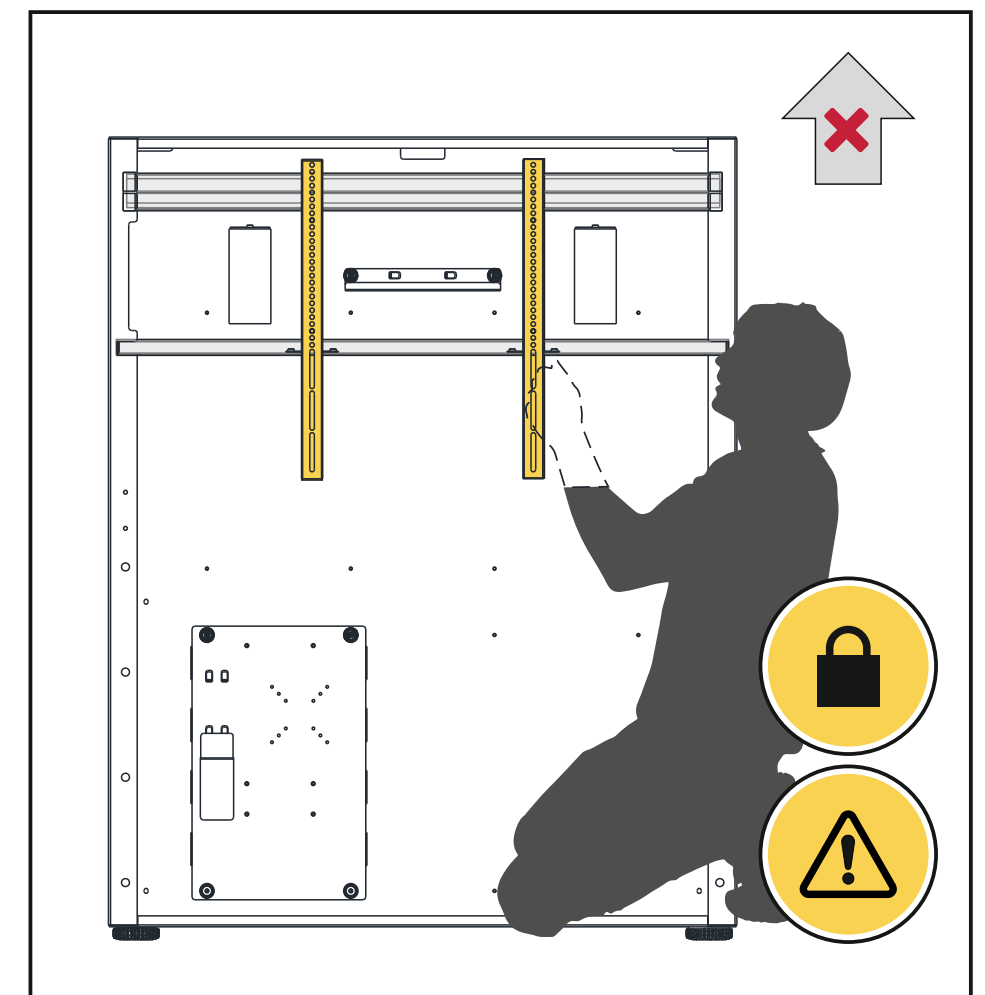

AB One - 55"/65"/75" - Camera Above.

Assembly Guide

7

CHASSIS PERIPHERALS

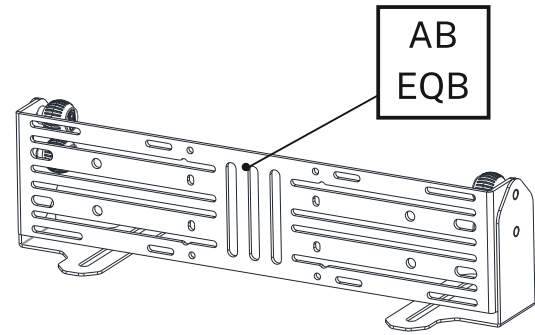

D

CAMERA BRACKET

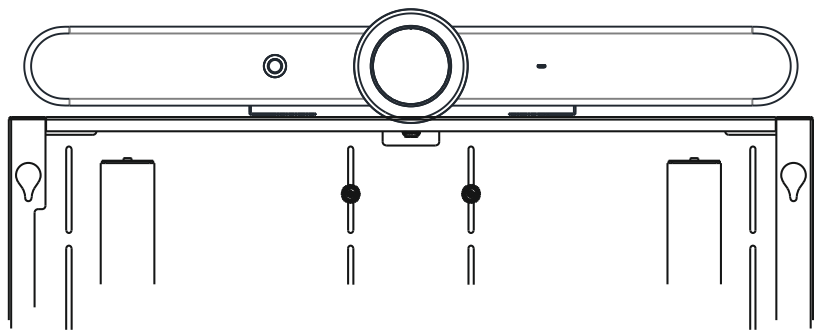

REFER TO SEPARATE GUIDES FOR DETAILED ASSEMBLY INFORMATION

7a

E

AB EQUIPMENT BRACKET

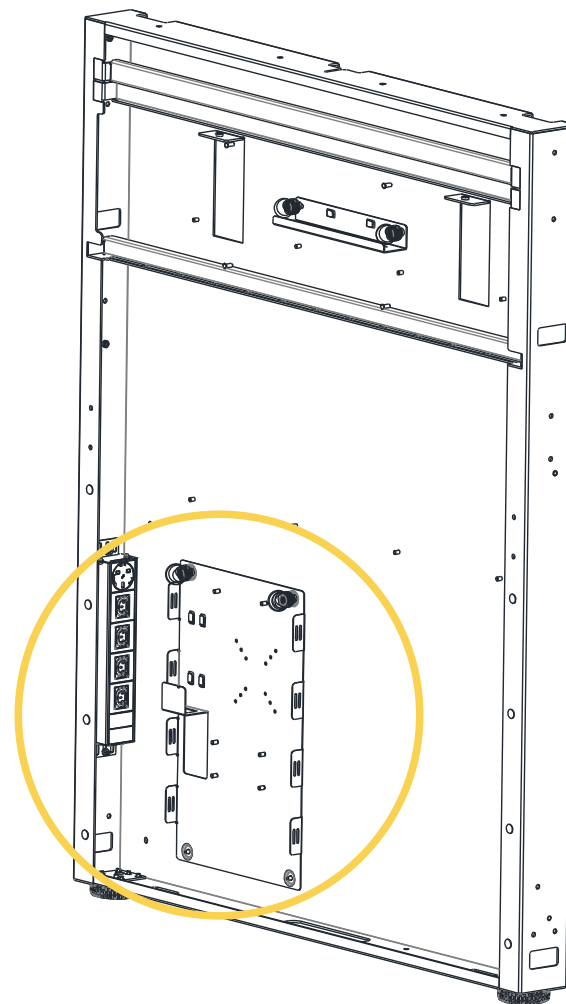
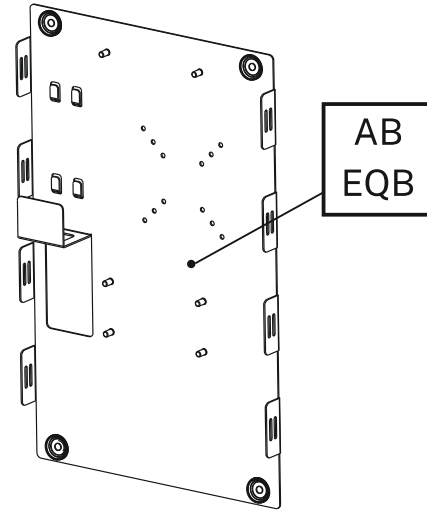

F

3RD PARTY EQUIPMENT BRACKET

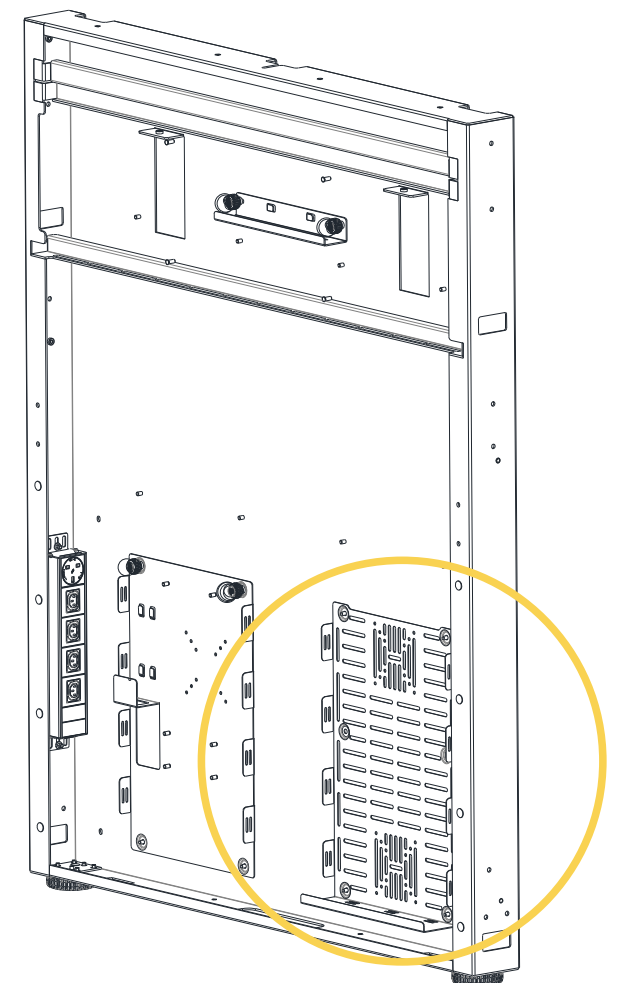
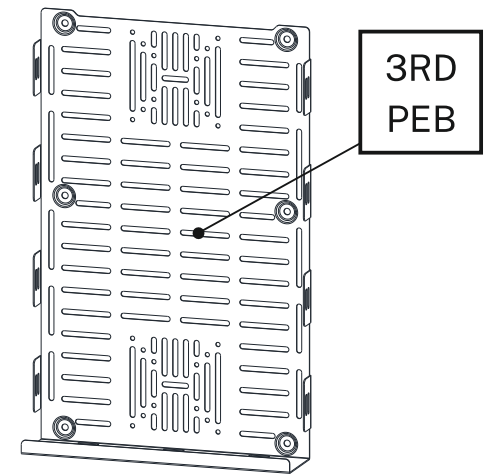

AB One - 55"/65"/75" - Camera Above.

Assembly Guide

