

1

2

3

4

5

6

7

8

CHANGE No	REV	DESCRIPTION	DRAWN	DATE
	01	ORIGINAL	AM	16-09-2022

A

B

C

D

E

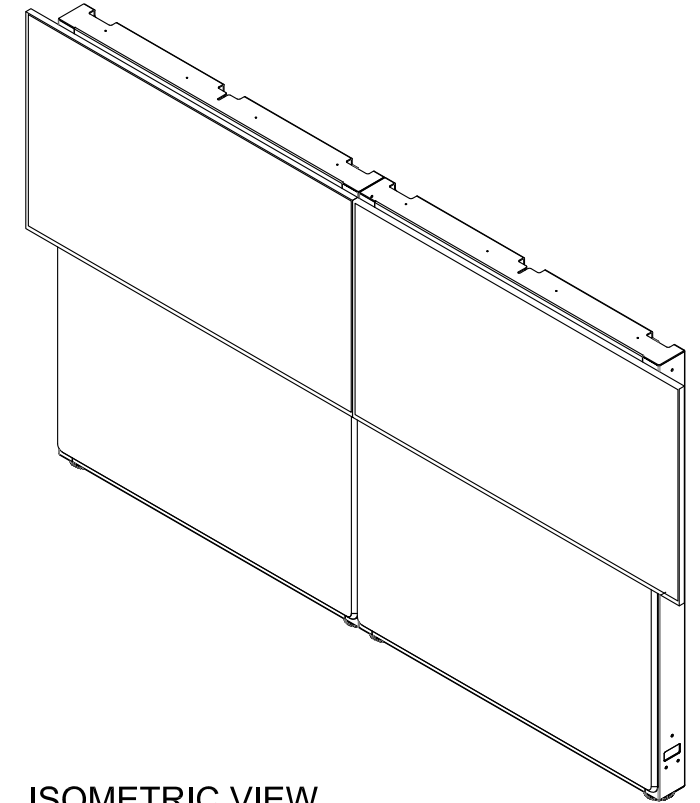
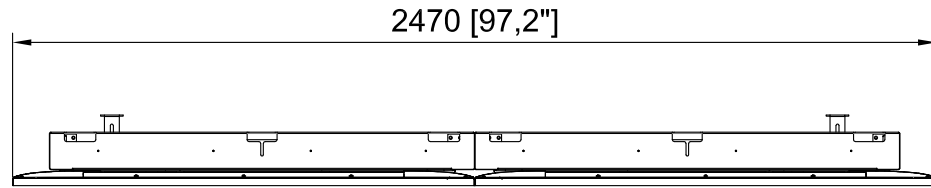

ISOMETRIC VIEW
Model shown with 2 x LG55UH5J-H

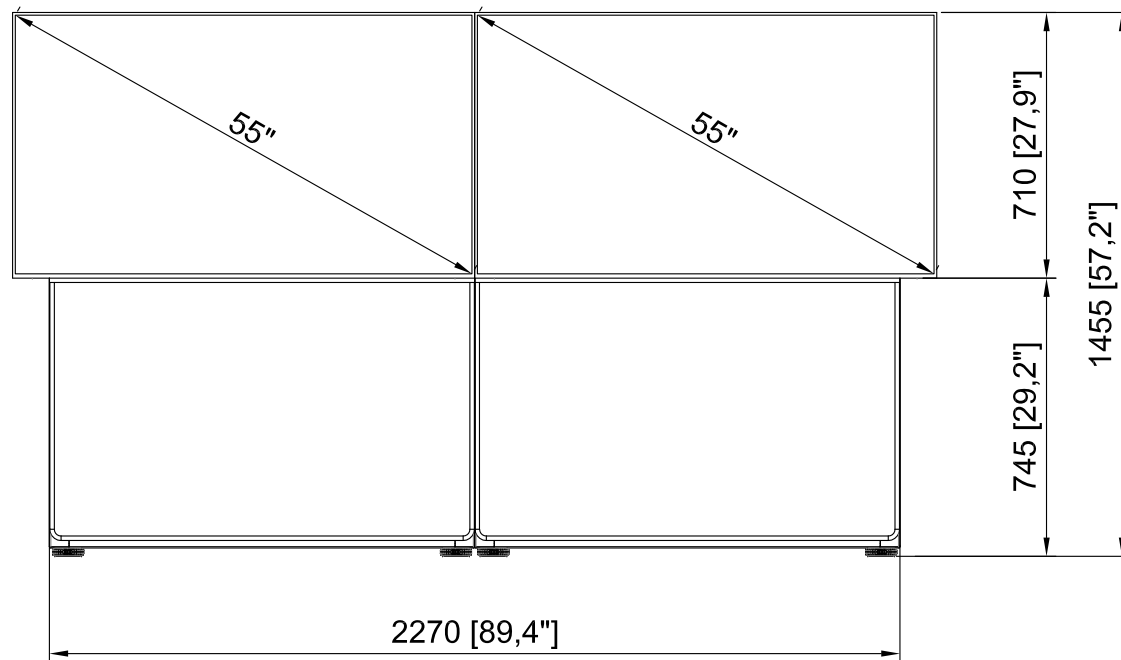
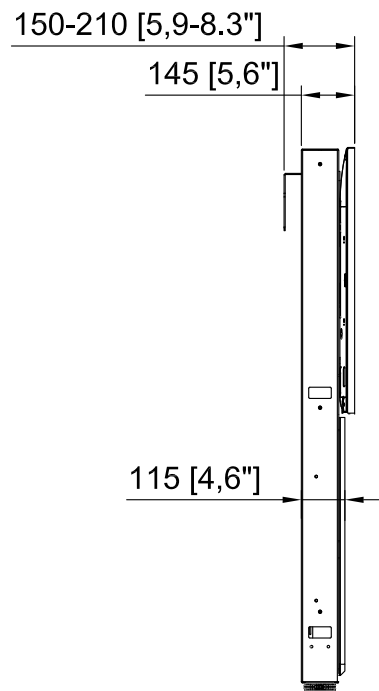

DO NOT SCALE DRAWING. SCALE NOTE(S) ARE SCALE REFERENCES RELATIVE TO MAIN VIEW ONLY AND MAY NOT REFLECT ACTUAL PART SIZE ON DRAWING. REMOVE SHARP EDGES UNLESS SPECIFIED.

THIS DOCUMENT CONTAINS CONFIDENTIAL INFORMATION. ALL ASPECTS OF ITS CONTENTS ARE PROTECTED BY COPYRIGHT LAW AND MAY NOT BE REPRODUCED IN ANY MANNER, OR FOR ANY PURPOSE, EXCEPT BY WRITTEN PERMISSION OF ASHTON BENTLEY TRADING LIMITED, THE COPYRIGHT HOLDER. THE ITEMS DETAILED IN THIS DRAWING ARE PROTECTED UNDER SEVERAL PATENTS.



ASHTON BENTLEY TRADING LIMITED
23 SCHOONER PARK, SCHOONER COURT,
CROSSWAYS BUSINESS PARK, DARTFORD, KENT, DA2 6NW
UNITED KINGDOM

DRAWN BY: A MESTRE
DATE: 16-09-2022

TITLE: Two55 - Overall Dimensions

APPROVED BY: R VINTON
DATE: 16-09-2022

DRAWING NUMBER: 740-00210

THIRD ANGLE PROJECTION:

DRAWING SIZE: A3
DIMENSIONS IN: MM [INCHES]
SCALE: 1:20
SHEET: 01 OF 1
REV: 01