



ADA

ADA Compliant Meeting Room Deployment



kramer | ab. Ashton Bentley.

Introduction



The Americans with Disabilities Act of 1990 (ADA) is a civil rights law that prohibits discrimination against individuals with disabilities.

The ADA Standards for Accessible Design were first published in 1991 and revised in 2010. These standards establish mandatory requirements for the design of public, government, and commercial facilities across the United States.

Compliance is not optional. These are legal standards that all applicable facilities must meet. When applied to meeting room design, the standards are generally straightforward to understand and implement. However, despite their relative simplicity, there are many common misunderstandings, particularly around how the standards apply to meeting room designs and the integration of audiovisual (AV) technology.

This document explains the key requirements and outlines how Ashton Bentley can help you design and build compliant meeting rooms.



*Life is
too short to worry
about stupid things.
Love less.
Fall in love.
Forget nothing
and don't let
people bring
you down.*

Mounting
Equipment to a wall

Equipment Protrusion



A significant hazard for blind, or partially sighted individuals is equipment that protrudes from a wall surface.

Objects extending into circulation paths may not be detected by a white cane, which typically identifies obstacles at floor level.

As a result, items mounted higher on walls can present a collision risk.

In meeting spaces, videobars and displays are often mounted directly to walls, making it essential to understand how the standards apply.

The standard specifies that objects mounted on walls with their leading edge positioned:

- More than 27" (685 mm) above the finished floor, and
- Less than 80" (2030 mm) above the finished floor

must not protrude more than 4" (100 mm) from the wall surface.

This means that many videobars currently on the market cannot be mounted directly to a wall (either above or below) a display because they project more than the permitted 4" (100 mm) from the wall surface, potentially making the installation non-compliant.

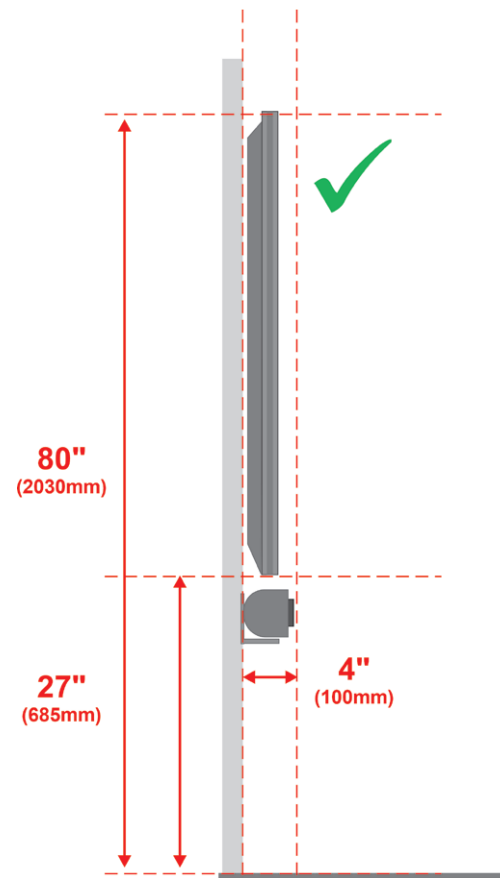

The standard

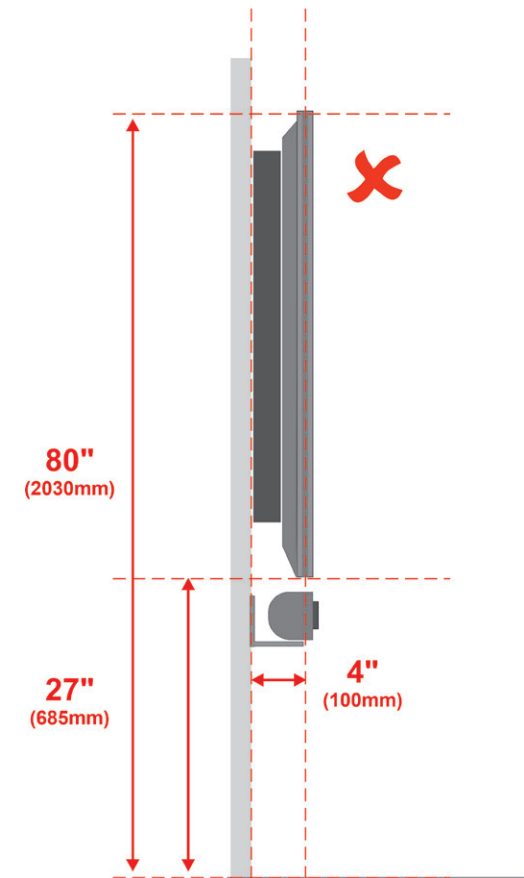

Not ADA compliant

The Ashton Bentley Solution



A compliant solution is to mount both the display and the videobar on an Ashton Bentley floor-supported Display Mount, rather than fixing them directly to the wall.

In this configuration, the front surface of the Display Mount becomes the reference point for measuring protrusion because the base extends to floor level and can be detected by a white cane.

This approach allows significantly deeper equipment to be installed without creating a protrusion hazard.

The videobar may be installed either above or below the display, provided it is recessed into the Display Mount. Both configurations are ADA compliant and provide a straightforward, solution for safely accommodating deeper videobars.

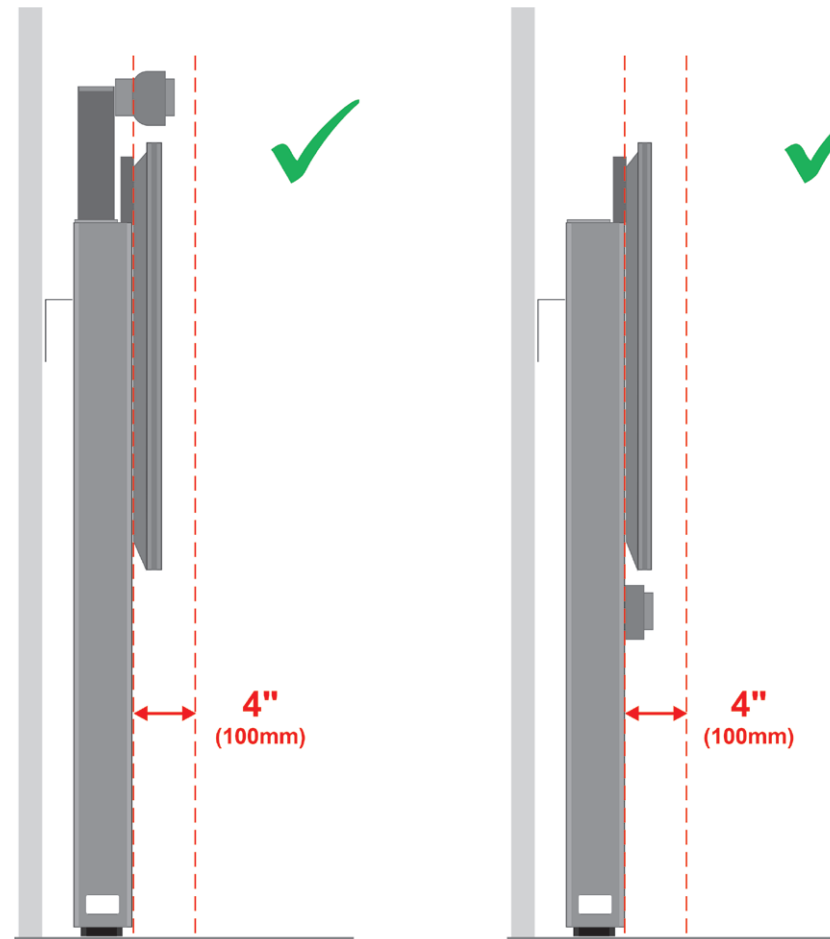

Equipment Extension Sideways



A floor-supported stand can resolve the ADA wall protrusion limits, however the display and videobar must not extend more than 12" (305 mm) beyond either side of the stand.

The stand itself can be detected by a white cane because it extends to the floor. If the display or videobar projects too far beyond the sides of the stand, the overhanging portion may not be detectable below 27", creating a potential collision hazard for blind or partially sighted individuals.

Most Ashton Bentley Display Mounts are designed to meet these requirements and provide a simple compliant solution.

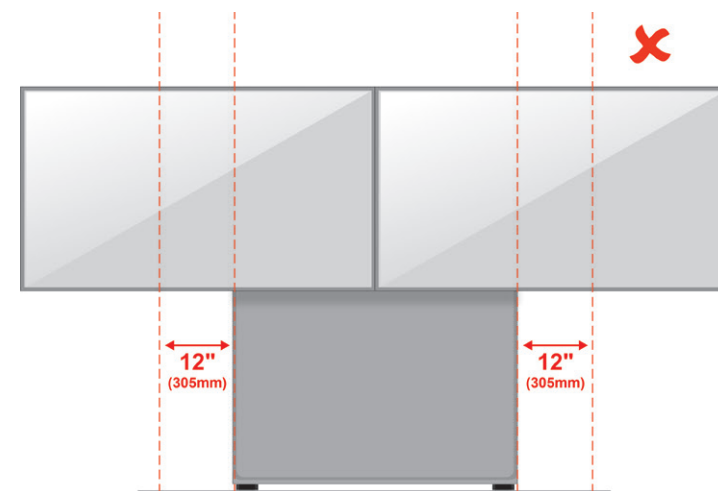
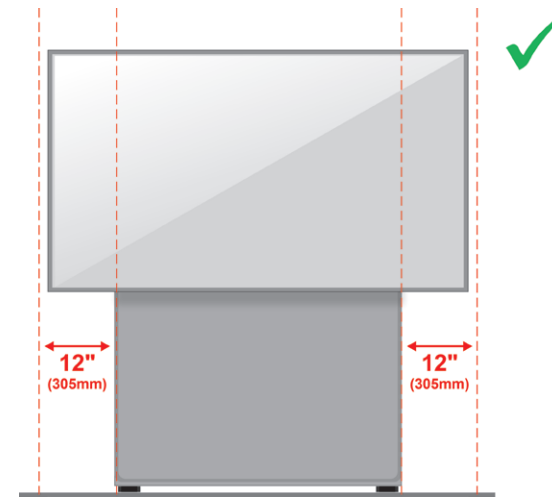

Large Format Displays



Some display stands, especially for large format displays (86", 98", 105", 120"), are pedestals with a shroud that wraps around the display(s). This usually means the entire assembly projects more than the permitted 4" from the wall and so not ADA compliant.

This can be compounded by the display(s) extending more than 12" on either side.

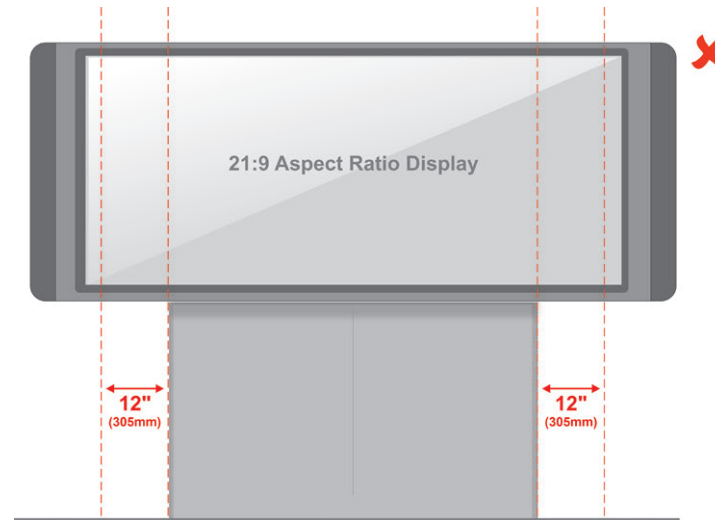

A compliant solution is to mount the display(s) on an Ashton Bentley floor-supported Display Mount.

Taking a 105" 21:9 display as an example, the stand must be at least 75.8" (1925 mm) wide to ensure the display does not extend more than 12" (305 mm) beyond either side of the stand.

The Ashton Bentley Display Mount is wide enough to provide a compliant solution.

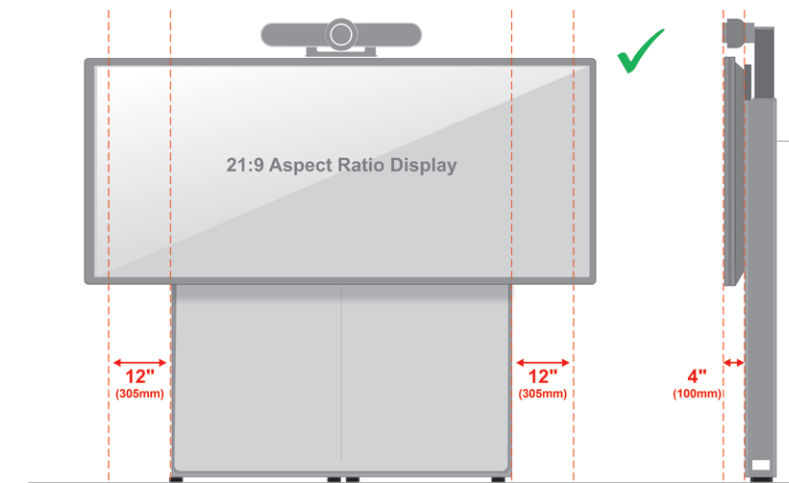



Exceptions.

The ADA Standards include an exception for temporary installations, but they do not define what “temporary” means.

Since ADA requirements for meeting rooms are generally easy to follow, it’s not advisable to rely on this exception.

Videobars and displays placed on freestanding pedestals or wheeled carts that then remain in the same location for some time, are unlikely to be considered temporary in a legal context.

It’s safer to assume all installations must fully comply with ADA standards.



Tables

Tables



The Standards for Accessible Design do not specifically address meeting room tables, but they do define reach limits for wheelchair users.

Typically meeting room tables have both power and connectivity located in the centre of the table concealed in boxes or 'troughs'. In many cases, especially in larger tables, out of reach for a wheelchair user.

This can constitute discrimination under ADA requirements.



Reach



According to Section 308.2.2 of the 2010 Standards, a wheelchair user must not be required to reach more than 44" (1118 mm) above the floor when a table extends more than 25" (635mm).

This means the user cannot reach more than approximately 25" across the table

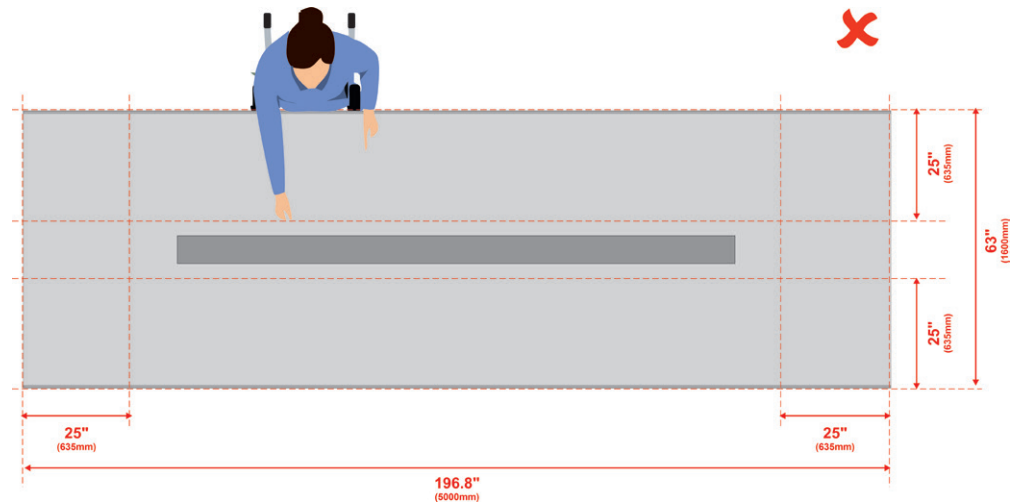
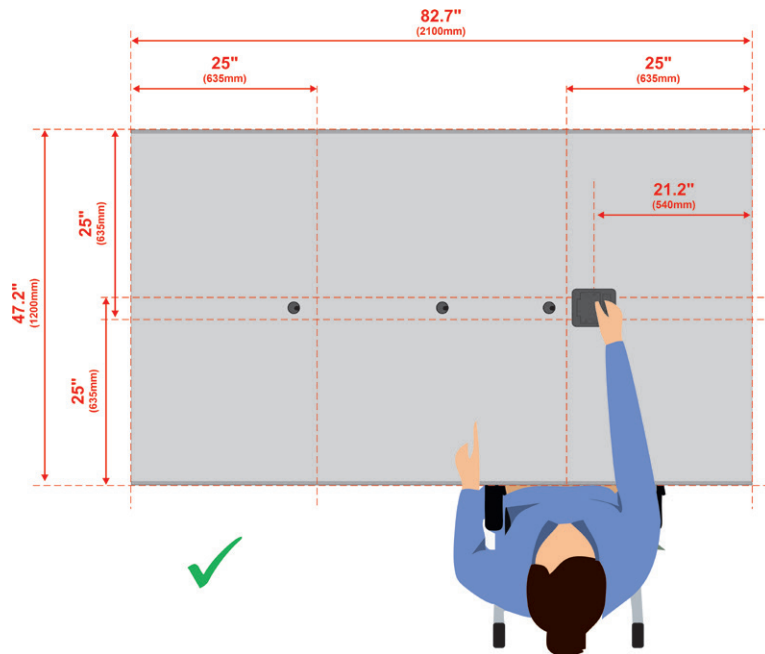
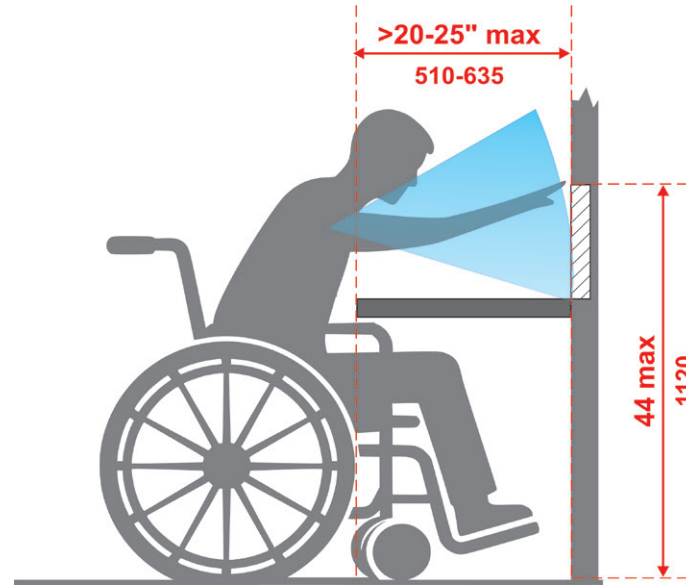

The Ashton Bentley Solution



Combining the recommendation from the standards with good accessibility design, we have developed our meeting room tables. Both power sockets and connectivity are within reach no matter the size of the table.

Connectivity

Laptop connectivity is concealed in a Tablebox within the recommended reach distance

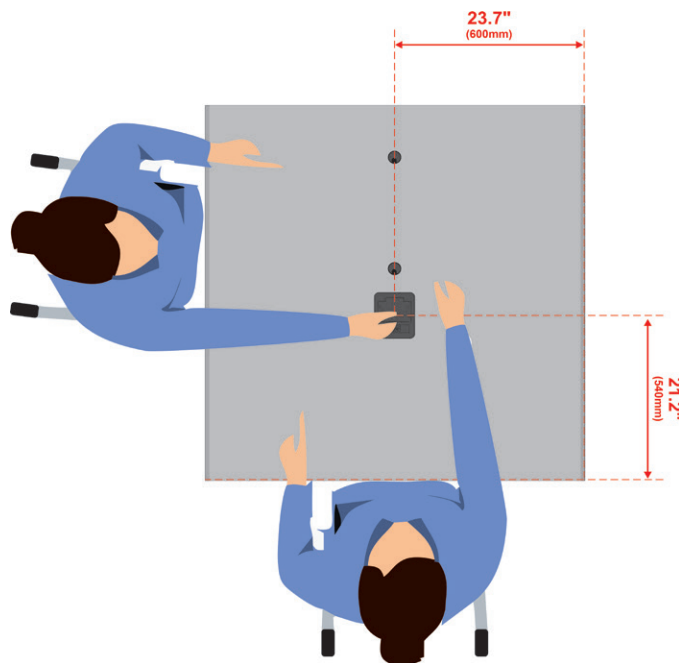

Power Sockets

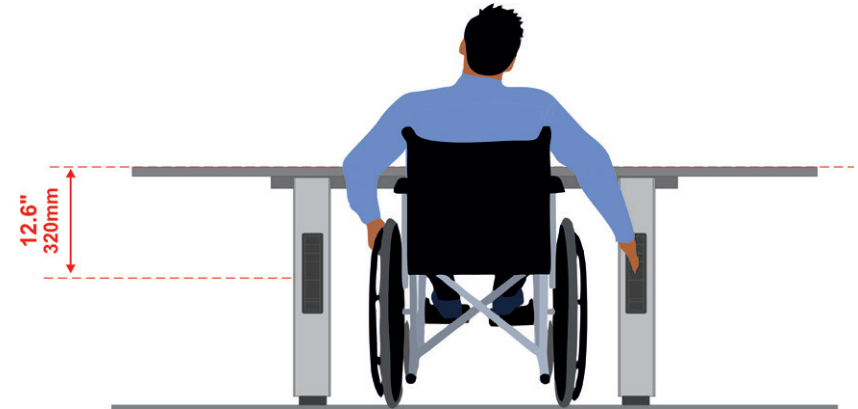

Side on View

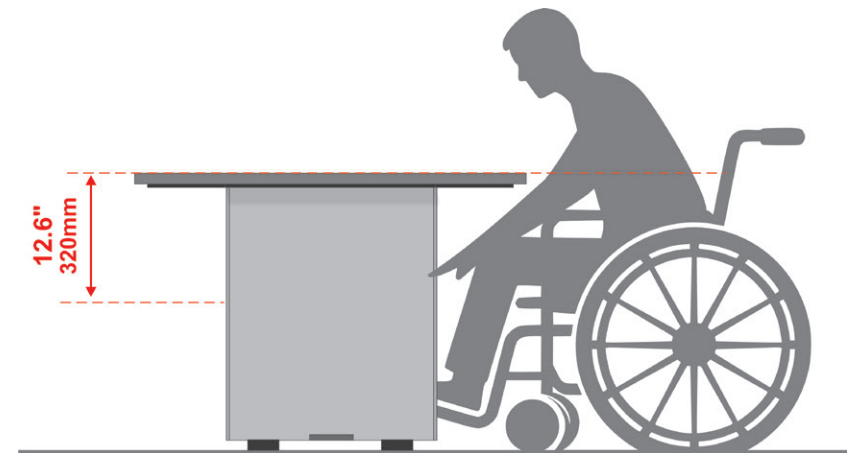

End on View

The Range - Camera Above



Single Display



AB One55



AB One65

Dual Display



AB Two55



AB Two65

Single Display



AB One86



AB One98

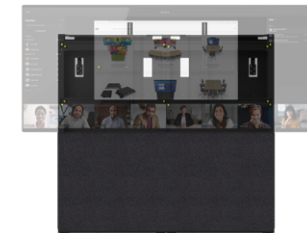

AB One05

Dual Display

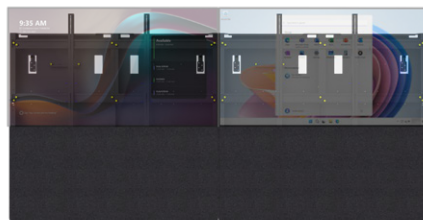

AB Two 86

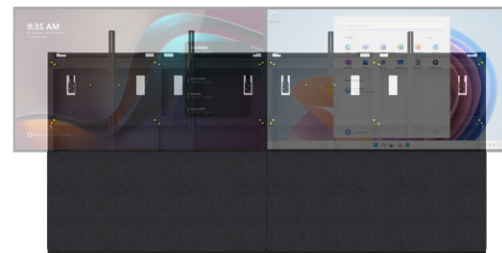

AB Two 98

The Range - Camera Below



Single Display



AB One 55



AB One 65

Dual Display

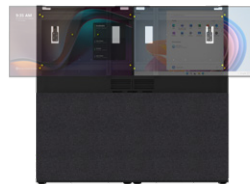

AB Two 55



AB Two 65

Single Display



AB One 86



AB One 98

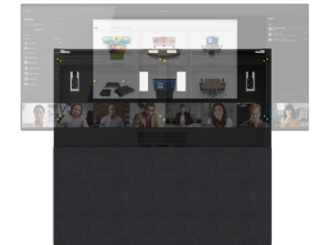

AB One 105

Dual Display



AB Two 86



AB Two 98

The Range - Tables



(ST) Shaped

Optimised for Video



ST5 - 5 Person



ST7 - 7 Person



ST9 - 9 Person



ST11 - 11 Person

(RT) Rectangular

Optimised for Space



RT5 - 5 Person



RT7 - 7 Person



RT9 - 9 Person



RT11 - 11 Person

(TP) Telepresence

Optimised for Engagement



TP4 - 4 Person



TP6 - 6 Person



Conclusions.

The Standards for Accessible Design ensure compliance with ADA regulations, which are a legal requirement in the United States. Since wall-mounted displays are very common, careful planning is required to ensure compliance.

Large displays can make compliance difficult, especially when a videobar or other equipment is also mounted on the wall or behind the display, increasing how far it projects from the wall.

Floor-to-wall Display Mounts from Ashton Bentley provide a simple solution. They can accommodate the depth of a videobar and related equipment. However, compliance still requires that:

- Displays do not extend 12" beyond the sides of the mount
- No equipment protrudes more than 4" from the front.

Although tables are not specifically covered in the standards, applying ADA wheelchair reach guidelines makes it relatively simple to determine suitable designs. Ashton Bentley tables have been designed around good accessibility best practice.

The standards are clear, but it is still easy to create a non-compliant or overly complicated installation. Careful design and a good understanding of the requirements are essential.





Ashton Bentley
23 Schooner Court
Crossways Business Park
Dartford
DA2 6NW
United Kingdom

t: +44 (0)207 100 1200
e: ab_spaces@kramerav.com
w: www.ashtonbentley.com

Ashton Bentley started 15 years ago with a small group of like-minded people who believed meeting room AV could, and should, be simpler.

What once felt like a bold idea is now becoming the norm, with industry heavy weights endorsing and promoting our (we are not biased) excellent products!

It hasn't always been a smooth ride, but it's been a fun one—and it turns out we weren't as mad as we first thought.

Much more to come!

© 2011-2025 Ashton Bentley Trading Limited. All rights reserved. Ashton Bentley®, the Ashton Bentley logo and the names and marks associated with Ashton Bentley's products are trademarks and/or service marks of Ashton Bentley Trading Limited, and are registered and/or common law marks in the United Kingdom, United States and various other countries. All other trademarks are property of their respective owners. No portion here may be reproduced or transmitted in any form or by any means, for any purpose other than the recipient's personal use, without the express written permission of Ashton Bentley.

Illustrations in this document might look different from your product. Content is subject to change without notice.

3rd party manufacturers may make periodic changes to the operational behaviour and features of their product(s). Please refer to their resources for the latest information.